

## Plate Heat Exchangers



HYDAC HEX Sxxx



Hxxx-LIQUID

### General

Plate heat exchangers are used wherever thermal energy (heat) has to be transferred from one fluid to another.

The advantage is that they can maintain the fluid temperature at a very low and stable level – depending on the temperature of the coolant.

Plate heat exchangers consist of a stack of stamped heat exchange plates which are either brazed together or bolted together in a frame with gaskets.

Medium flows in the channels between the plates where hot medium (which will be cooled) alternates with cold medium (which will be heated). The design of the plates induces the turbulent flow required for efficient heat transfer.

### Brazed plate heat exchangers HYDAC HEX Sxxx

The design and construction of the **brazed plate heat exchangers** are particularly compact and efficient. The heat transfer plates are made in stainless steel and are brazed with copper as standard. For use with aggressive media, nickel braze can also be used.

Copper brazed plate heat exchangers are pressure resistant up to 30 bar, nickel brazed up to 10 bar. Special models are however also suitable for higher pressures.

### Gasketed plate heat exchangers Hxxx-LIQUID

**Gasketed plate heat exchangers** are particularly suitable for large flows and high cooling capacities. The stack of heat transfer plates and gaskets is clamped together with bolts in a frame.

This means that the plate heat exchanger can also be dismantled for cleaning and maintenance. Furthermore it is possible to add more plates at a later date to achieve a higher capacity.

For applications with seawater, the plate heat exchangers can also be supplied with titanium heat transfer plates.

Various stamp designs can cater for heavily contaminated or high viscosity fluids to suit particular applications, or even if the temperature difference between the hot and cold medium is only minimal.

**Safety heat exchangers** with double-walled plates are used in situations where different media must be strictly isolated.

## Function

Fluids flow in counterflow through the plate heat exchanger:

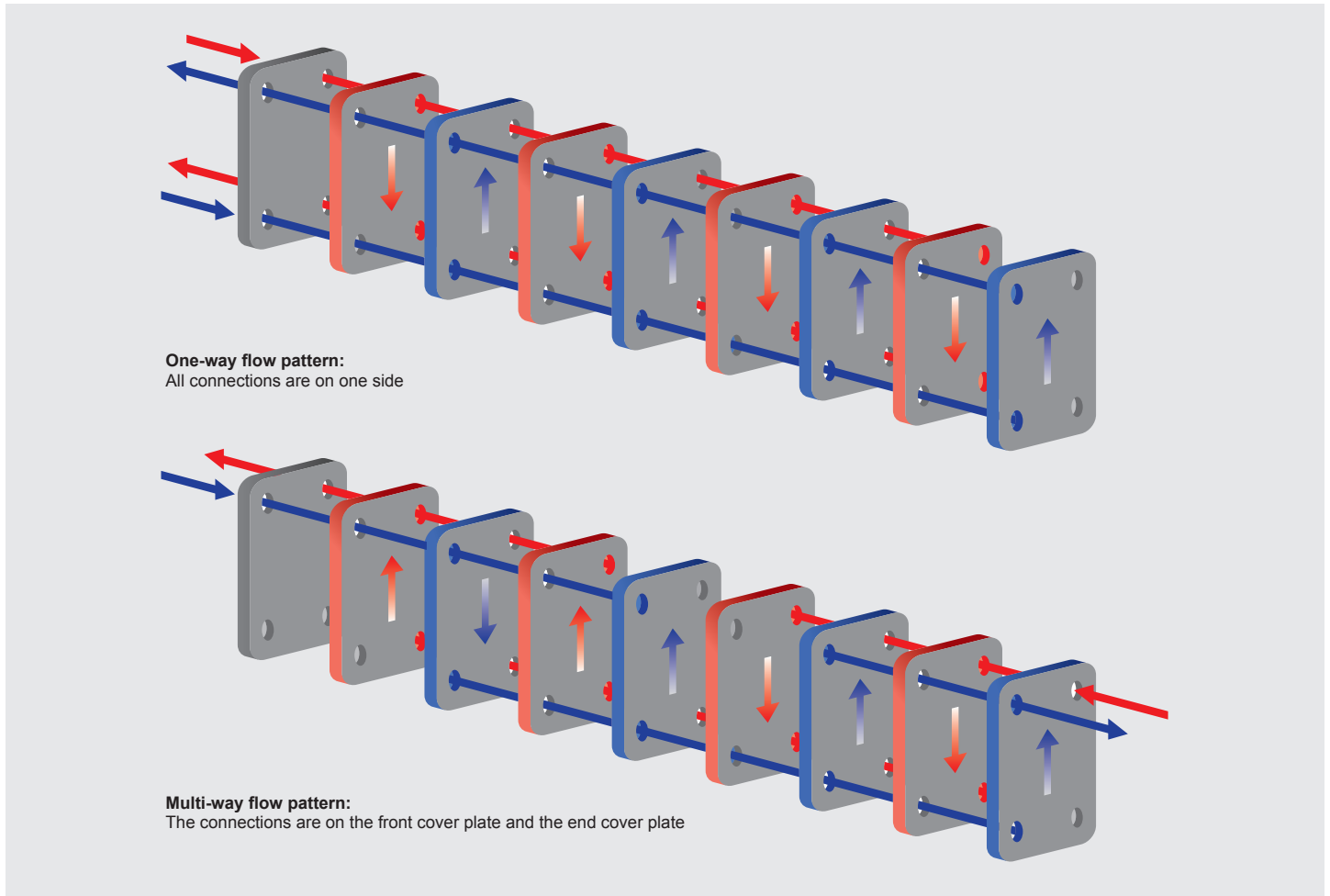

In counterflow, the hot medium is cooled more rapidly than in parallel flow because the cold medium flows in the opposite direction to the hot fluid.

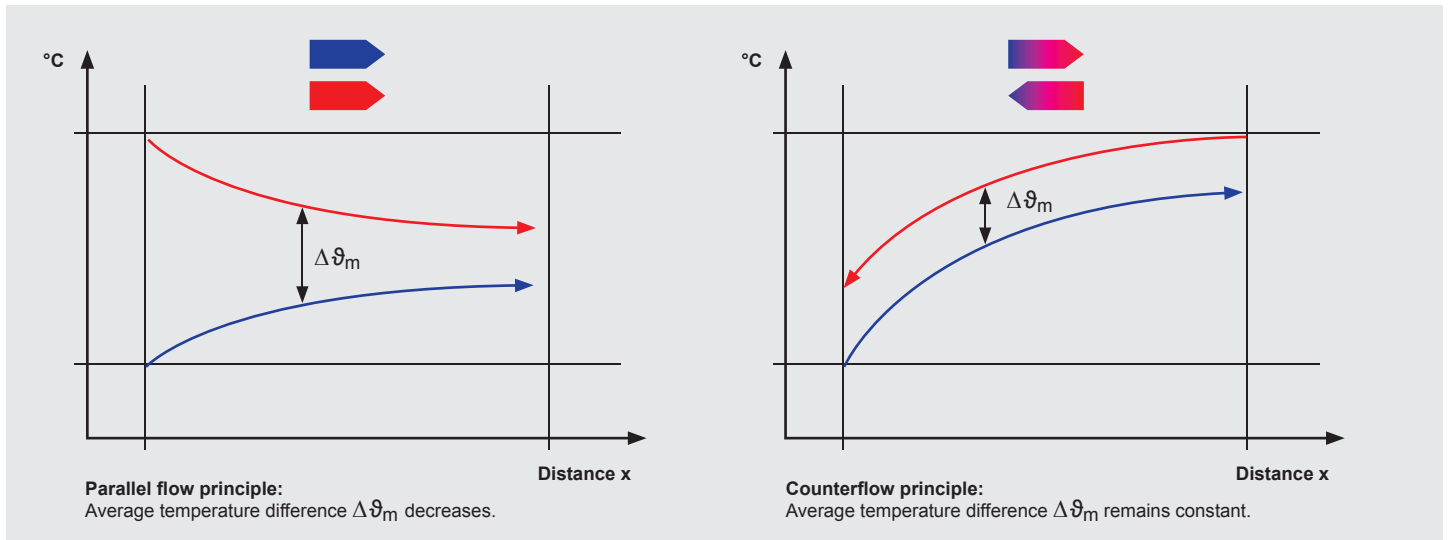

With **brazed plate heat exchangers** it is possible to reverse the inlet and outlet connections of a medium without adversely affecting the function. However, to guarantee the counterflow principle, the inlet and outlet of the other medium must also be changed. However, changing the cold and hot side is not recommended. The plate heat exchangers are designed to have hot fluid always flowing through the outer plate. If cold medium flows through, condensation could form on the outside of the heat exchanger.

With **gasketed plate heat exchangers** it is not possible to change the connections because of the more complex plate stamp pattern. In this case the connections can be selected before manufacture of the plate heat exchanger. Please consult our technical sales department.

## Area of application

A plate heat exchanger can be used wherever there should be heat transfer between two media.

Typical applications are:

- Hydraulic systems
- Presses
- Lubrication systems
- Test rigs
- Motors/engines

## Sectional view

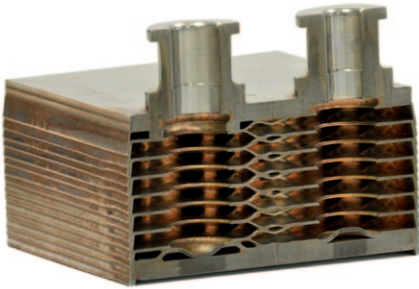

Cross-section of a brazed plate heat exchanger

## Cooling capacity

The maximum cooling capacity of a plate heat exchanger depends on several factors:

- the inlet temperature of the hot and cold medium
- the flow rate of the hot and cold medium
- the media used.

## Sizing program

The sizing program for **brazed plate heat exchangers** helps you to select the right size and number of plates.

Please ask for the latest version from the technical sales department.

Type	Plate No.	Series	Parallel	Required heat load kW	Margin %	Press. drop of side 1 bar	Press. drop of side 2 bar	Note
HEX S400								No Solution
HEX S610	110	1	1	10,0	-1,6	0,01	0,03	
HEX S615	30	1	1	10,0	2,0	0,07	0,19	
HEX S522	30	1	1	10,0	30,7	0,01	0,06	
HEX S722	30	1	1	10,0	15,3	0,01	0,06	

PHE: **HEX S615** PDF Drawing

For **gasketed plate heat exchangers** please fill in the Specification Sheet in this brochure and send it to the technical sales department.

We will help you to find the appropriate plate heat exchanger for your specific application.

## Specification sheet for plate heat exchangers

In order to be able to make the correct selection, it is necessary to have various data to hand.  
The following check-list is designed to help.

Project: \_\_\_\_\_

Contact: \_\_\_\_\_

Telephone: \_\_\_\_\_

E-mail: \_\_\_\_\_

### General

Design pressure \_\_\_\_\_ bar

### Hot side

Medium to be cooled  Oil ISO VG \_\_\_\_\_ SAE \_\_\_\_\_  
 Water  
 Water glycol % Glycol: \_\_\_\_\_ %  
 Other medium  
(Please attach technical datasheet for medium, if available.)

Inlet temperature: \_\_\_\_\_ °C

Flow rate: \_\_\_\_\_ l/min or \_\_\_\_\_ m<sup>3</sup>/h

Max. pressure drop: \_\_\_\_\_ bar

Required cooling capacity: \_\_\_\_\_ kW

or

Outlet temperature: \_\_\_\_\_ °C

### Cold side

Cooling medium:  Oil ISO VG \_\_\_\_\_ SAE \_\_\_\_\_  
 Water  
 Seawater (Gasketed PWT only)  
 Water glycol % Glycol: \_\_\_\_\_ %  
 Other medium  
(Please attach technical datasheet for medium, if available.)

Inlet temperature: \_\_\_\_\_ °C

Flow rate: \_\_\_\_\_ l/min or \_\_\_\_\_ m<sup>3</sup>/h (if known)

Max. pressure drop: \_\_\_\_\_ bar

### Comments

---

---

---

---

---

---



## Brazed Plate Heat Exchangers HYDAC HEX Sxxx

### Symbol

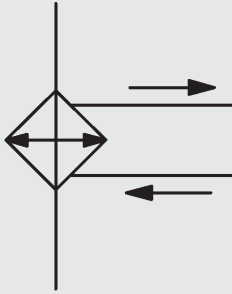

### General

With plate heat exchangers, the heat from the fluid being cooled is transferred to a cooling fluid. The advantage is that they can maintain the fluid temperature at a very low and stable level – depending on the temperature of coolant. Brazed heat exchangers therefore ensure efficient heat transfer combined with compact dimensions and low weight.

### Product features

Brazed heat exchangers consist of a stack of stamped heat transfer plates with connections in stainless steel. The plates are vacuum brazed with copper or nickel.

The plates have smoothed edges and the end plate is provided with edge protection.

The special stamp pattern of the plates induces a turbulent flow which is necessary for optimum heat transfer and which in addition has a self-cleaning effect because the high level of wall friction reduces deposits on the surface.

### Operating data

Plate material	Stainless steel 1.4401 (AISI 316)
Braze material	Copper (standard), nickel
Pressures	Copper braze: max. 30 bar (test pressure 45 bar) Nickel braze: max. 10 bar Other pressures on request
Media	<ul style="list-style-type: none"> <li>● Hydraulic oil, lubrication oil, rolling oil, engine oil</li> <li>● HFC, HFA, HFD, pressure fluids</li> <li>● Water, water glycol</li> <li>● Refrigerant</li> </ul> Use nickel-brazed plate heat exchangers with corrosive fluids: e.g. ammonia, sulphides and sulphates, deionised or demineralised water Other fluids on request
Temperature range	up to +200 °C (freezing point and boiling point must be taken into consideration)
Contamination	The quantity of particles in suspension should be less than 10 mg/l Particle size <0.6 mm (spherical) Thread-like particles cause a rapid rise in pressure drop
Water quality	The following ions are not corrosive under normal conditions: phosphate, nitrate, nitrite, manganese, sodium and potassium See table on water quality
Connections	Female thread (standard) Optional: male thread, soldered connection, SAE connection
Accessories	Installation: HYDAC clamping bands (standard), optional: bolts on the front plate or the end plate Insulation

## Area of application

Cooling circuits operated using water, coolant, HFC operating fluid or oil.

Typical applications are:

- Machine tools
- Presses
- Injection moulding machines
- Motors/engines
- Test rigs
- Generators

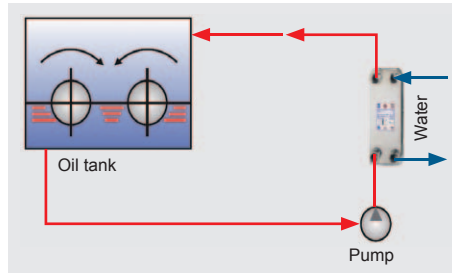

Oil cooling

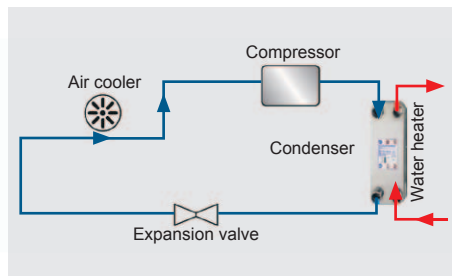

Heat pump

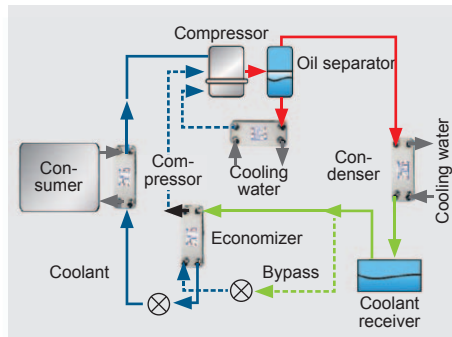

Chiller

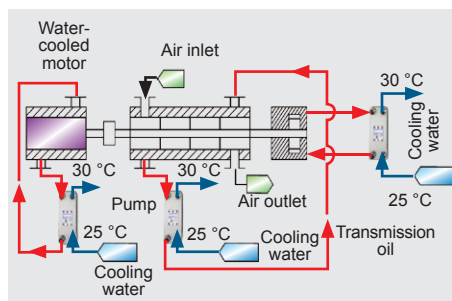

Vacuum pump

## Model Code

HYDAC HEX S400 -10 -00NI / G3/4"

### Size

HYDAC HEX S400  
HYDAC HEX S610  
HYDAC HEX S615  
HYDAC HEX S522  
HYDAC HEX S722  
HYDAC HEX Z800

Other sizes on request

### Number of plates

	10	14	20	30	40	50	60	70	80	90	100	120	150	160	180	190
HYDAC HEX S400	•	•	•	•	•											
HYDAC HEX S610	•	•	•	•	•	•	•	•	•	•	•	•	•	•	•	•
HYDAC HEX S615	•	•	•	•	•	•	•	•	•	•	•	•	•	•	•	•
HYDAC HEX S722			•	•	•	•	•	•	•	•	•	•	•	•	•	•
HYDAC HEX S522			•	•	•	•	•	•	•	•	•	•	•	•	•	•

### Version with nickel braze (optional)

### Connections (standard)

HYDAC HEX S400: 4 x G<sup>3/4</sup>" female thread

HYDAC HEX S610 and HYDAC HEX S615: 4 x G1" female thread

HYDAC HEX S722: 4 x G1½" female thread

HYDAC HEX S522: 4 x G1½" female thread

Male threaded, soldered and SAE connections are also available as an option. The pipes must be connected so that connections are stress-free.

Linear expansion and vibrations from the pipes to the heat exchanger must be avoided.

## Water quality

The following limits refer to copper-brazed plate heat exchangers and a water temperature of + 60°C:

Substances dissolved in water	Concentration	Stainless steel	Copper
pH value	<6.0 6.0 – 9.0 >9.0	0 0/+ +	0 + 0
Electrical conductivity	<500 [µ S/cm] >500 [µ S/cm]	+ +	+ 0
Cl <sup>-</sup>	<300	+ 0	+ 0
SO <sub>4</sub> <sup>-2</sup>	<50 50 – 300 >300	+ + 0	+ 0 0
CaCO <sub>3</sub>	<50 >50	+ 0	+ 0
Fe	<0.3 >0.3	+ +	+ 0
NH <sub>3</sub>	<2 2 – 20 >20	+ + +	+ 0 0
NO <sub>3</sub>	<100 >100	+ +	+ 0
S <sup>-2</sup>		Not suitable	
SiO <sub>2</sub>	<30	+	+
NH <sub>4</sub> <sup>+</sup>	<0.1	+	+
Free chlorine	<0.1	+	+
CO <sub>3</sub> <sup>-2</sup>	<0.4	+	+

0: Corrosive

+: Suitable

For nickel-brazed versions, please contact the technical sales department.

## Dimensions

### HYDAC HEX S400

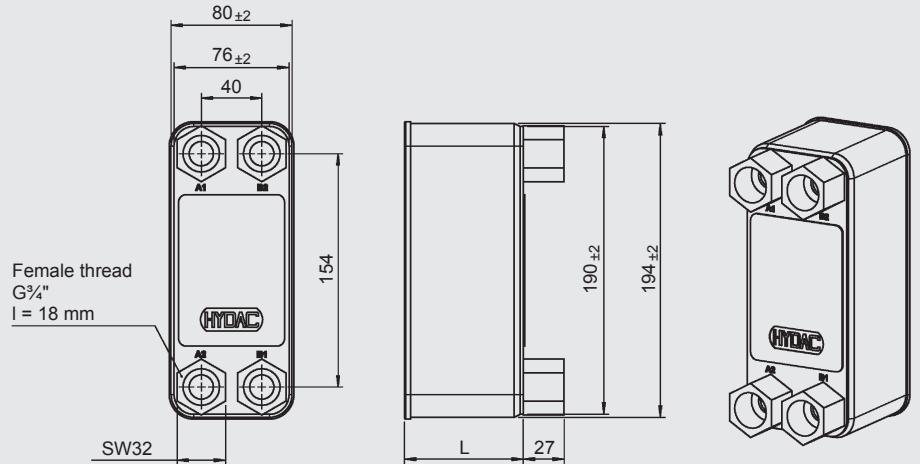
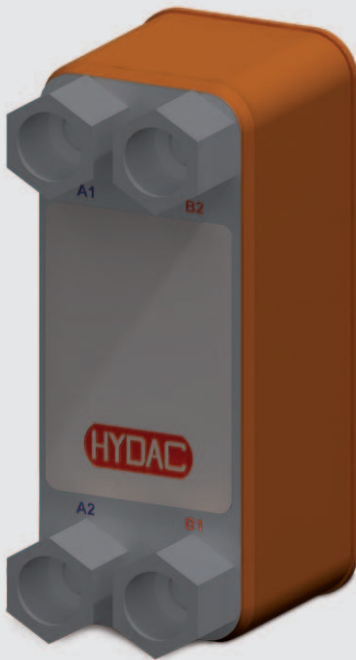

HYDAC Part No.	HYDAC Type Code	Dimension L [mm]	Weight [kg]
3455621	HYDAC HEX S400-10-00/G3/4"	33	1.3
3383847	HYDAC HEX S400-14-00/G3/4"	42	1.5
3455623	HYDAC HEX S400-20-00/G3/4"	55	1.8
3399435	HYDAC HEX S400-30-00/G3/4"	78	2.3
3455655	HYDAC HEX S400-40-00/G3/4"	101	2.8

### HYDAC HEX S610

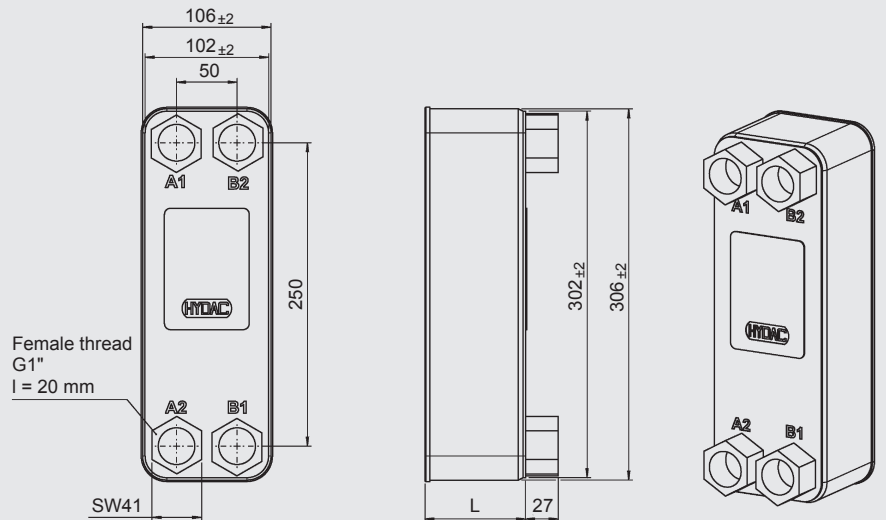

HYDAC Part No.	HYDAC Type Code	Dimension L [mm]	Weight [kg]
3366746	HYDAC HEX S610-10-00/G1"	34	2.5
3361012	HYDAC HEX S610-20-00/G1"	58	4.2
3366754	HYDAC HEX S610-30-00/G1"	82	5.5
3366759	HYDAC HEX S610-40-00/G1"	106	6.9
3366760	HYDAC HEX S610-50-00/G1"	130	8.25
3366761	HYDAC HEX S610-60-00/G1"	154	9.6
3366762	HYDAC HEX S610-70-00/G1"	178	10.9
3527300	HYDAC HEX S610-80-00/G1"	202	11.0
3366763	HYDAC HEX S610-100-00/G1"	250	14.2
3366764	HYDAC HEX S610-120-00/G1"	298	16.6



## HYDAC HEX S615

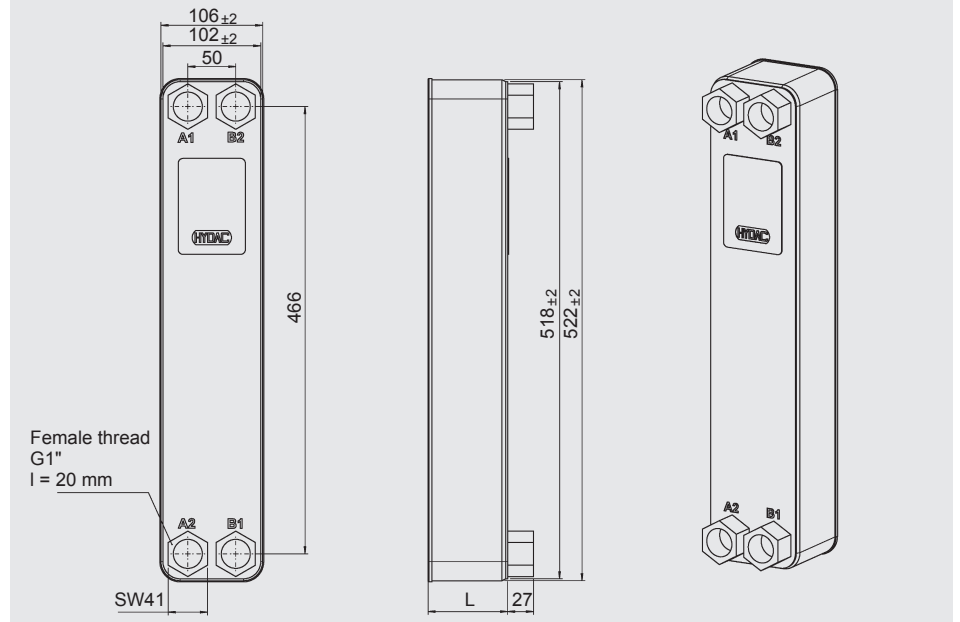

HYDAC Part No.	HYDAC Type Code	Dimension L [mm]	Weight [kg]
3366787	HYDAC HEX S615-10-00/G1"	34	5.3
3366788	HYDAC HEX S615-20-00/G1"	58	7.5
3366790	HYDAC HEX S615-30-00/G1"	82	9.7
3366792	HYDAC HEX S615-40-00/G1"	106	11.9
3366793	HYDAC HEX S615-50-00/G1"	130	14.1
3366794	HYDAC HEX S615-60-00/G1"	154	16.3
3366815	HYDAC HEX S615-80-00/G1"	202	20.7
3383853	HYDAC HEX S615-100-00/G1"	250	25.7

## HYDAC HEX S722

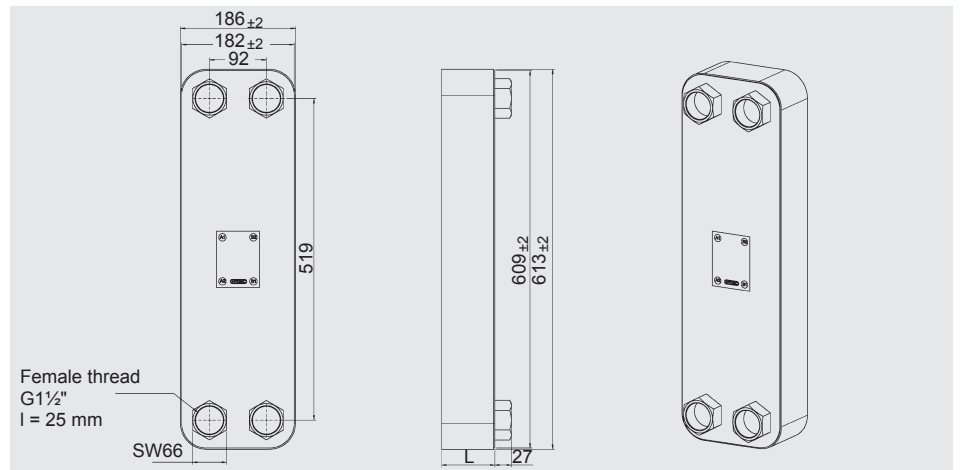
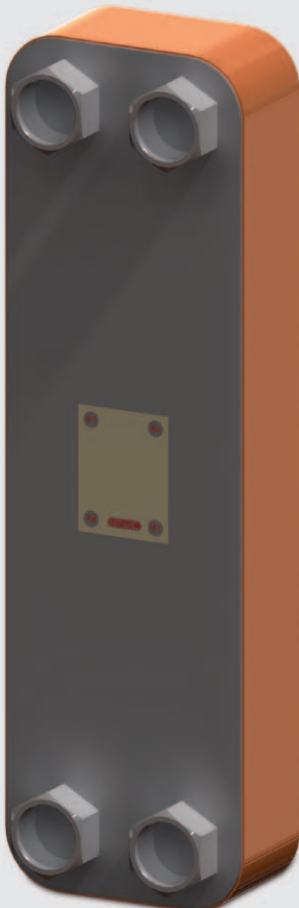

HYDAC Part No.	HYDAC Type Code	Dimension L [mm]	Weight [kg]
3457465	HYDAC HEX S722-20-00/G1 1/2"	62	15.3
3457473	HYDAC HEX S722-30-00/G1 1/2"	86	19.4
3457474	HYDAC HEX S722-40-00/G1 1/2"	110	23.5
3457486	HYDAC HEX S722-50-00/G1 1/2"	134	27.6
3457489	HYDAC HEX S722-60-00/G1 1/2"	158	31.7
3457490	HYDAC HEX S722-70-00/G1 1/2"	182	35.8
3457491	HYDAC HEX S722-80-00/G1 1/2"	206	40.0
3457493	HYDAC HEX S722-90-00/G1 1/2"	230	44.0
3457494	HYDAC HEX S722-100-00/G1 1/2"	254	48.0
3457495	HYDAC HEX S722-120-00/G1 1/2"	302	53.4
3457496	HYDAC HEX S722-150-00/G1 1/2"	374	69.0
3673112	HYDAC HEX S722-160-00/G1 1/2"	394	72.7
3463069	HYDAC HEX S722-190-00/G1 1/2"	470	84.8



## HYDAC HEX S522

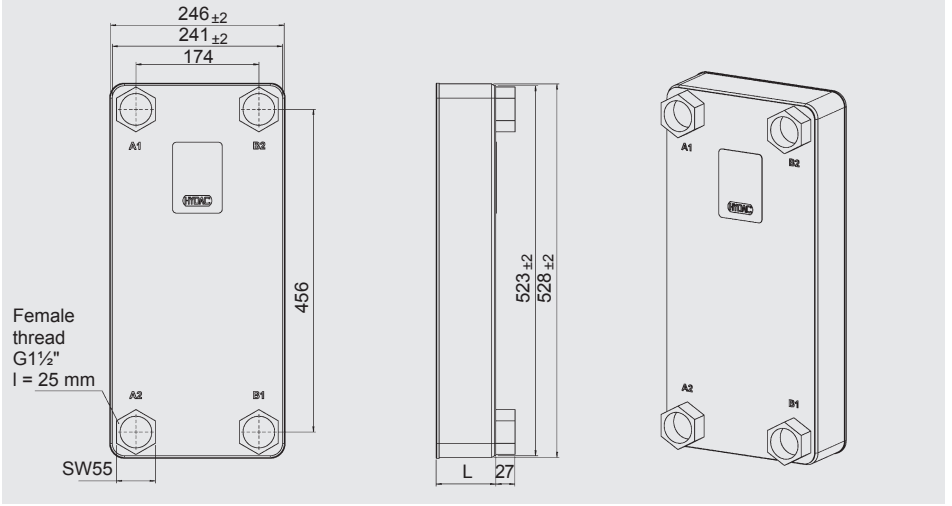
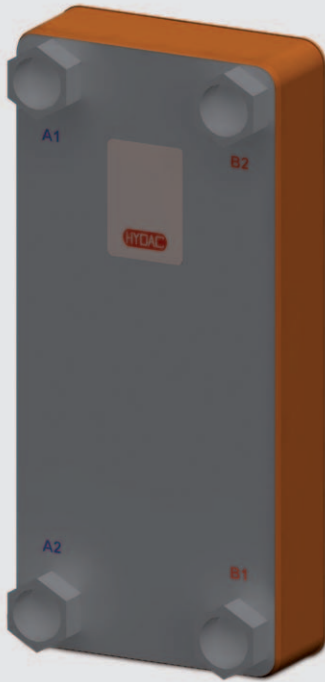

HYDAC Part No.	HYDAC Type Code	Dimension L [mm]	Weight [kg]
3383854	HYDAC HEX S522-20-00/G1 1/2"	60	17.6
3383906	HYDAC HEX S522-30-00/G1 1/2"	84	22.8
3383908	HYDAC HEX S522-40-00/G1 1/2"	108	28.0
3383909	HYDAC HEX S522-50-00/G1 1/2"	132	31.2
3383910	HYDAC HEX S522-60-00/G1 1/2"	156	38.4
3383911	HYDAC HEX S522-70-00/G1 1/2"	180	43.6
3383913	HYDAC HEX S522-80-00/G1 1/2"	204	48.8
3383914	HYDAC HEX S522-100-00/G1 1/2"	252	59.2
3651724	HYDAC HEX S522-110-00/G1 1/2"	276	60.8
3383925	HYDAC HEX S522-120-00/G1 1/2"	300	69.6
3383926	HYDAC HEX S522-150-00/G1 1/2"	372	85.2
3738950	HYDAC HEX S522-160-00/G1 1/2"	396	84.8
3383927	HYDAC HEX S522-190-00/G1 1/2"	468	106.0

## HYDAC HEX Z800

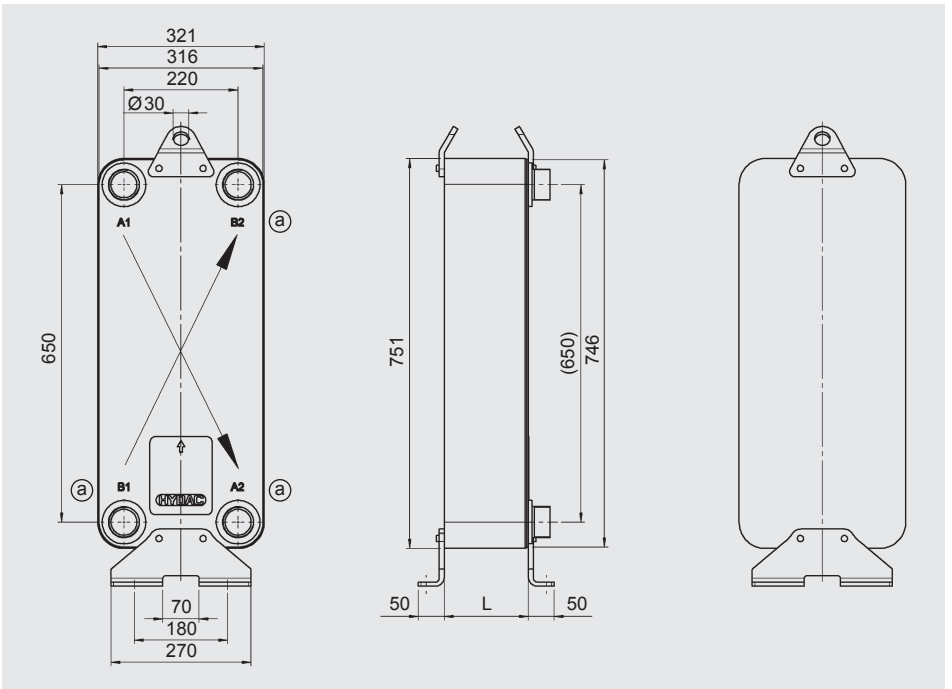

**Special size for high cooling capacities and large volumes:**

- Diagonal flow pattern
- Connections: threaded bolts with female or male threads, flange, soldered or SAE connections

## Installation

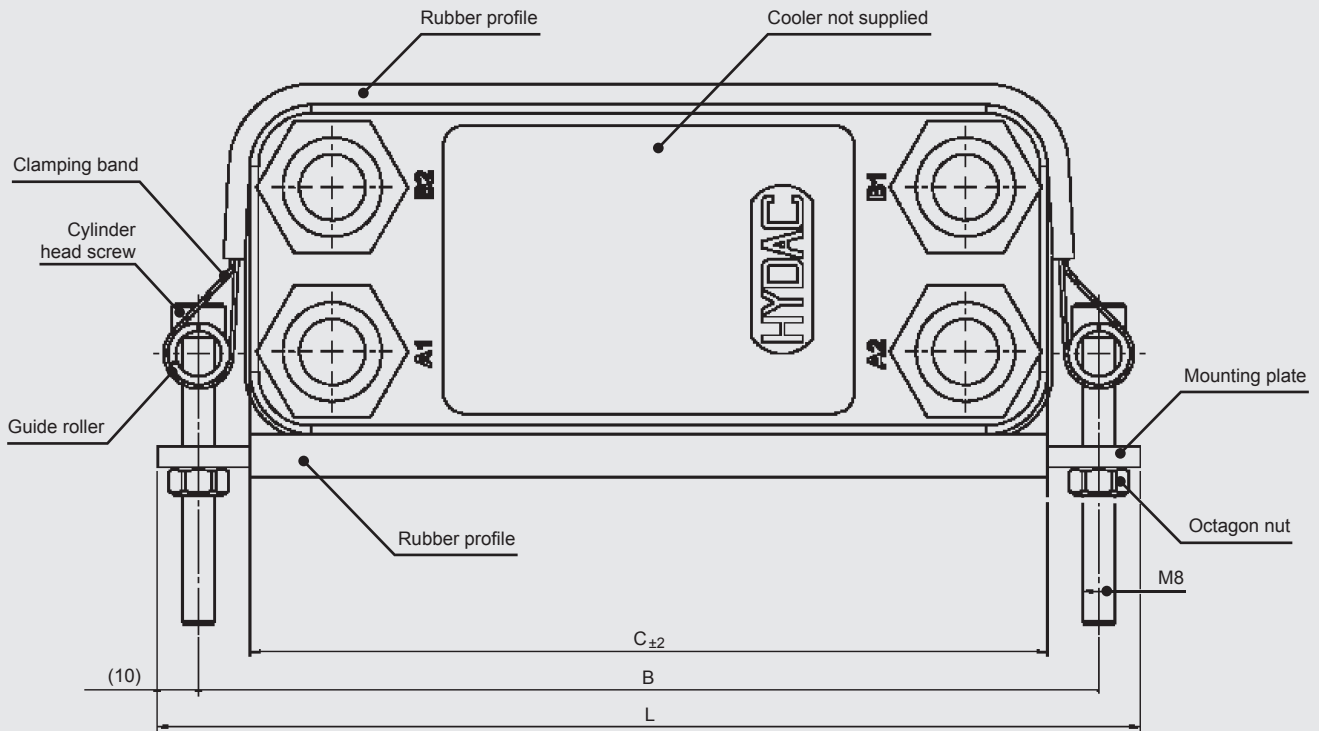

HYDAC Part No.	HYDAC Type Code	c [mm]	d [mm]	l [mm]	b [mm]
3092917	HYDAC HEX S400	194	80	239	219
3014028	HYDAC HEX S610	306	106	351	331
3014029	HYDAC HEX S615	522	106	566	546
3343306	HYDAC HEX S522	528	246	573	553
3013884	HYDAC HEX S722	613	186	658	638



## Symbol

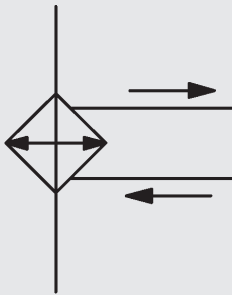

## General

With plate heat exchangers, the heat from the fluid being cooled is transferred to a cooling fluid. The advantage is that they can maintain the fluid temperature at a very low and stable level – depending on the temperature of coolant.

Gasketed plate heat exchangers are particularly suitable for large flows and high cooling capacities and are therefore a useful supplement to the brazed range.

## Product features

Gasketed plate heat exchangers consist of a stack of individually stamped heat transfer plates and gaskets. The plate stack is clamped using bolts in a frame consisting of a fixed cover and a moveable cover. The advantage is that the plate heat exchanger can also be dismantled for cleaning and maintenance. Furthermore it is possible to add more plates at a later date to achieve a higher capacity.

There are several sizes with varying numbers of plates and different stamp designs available to cover the capacity range. In this way they can cater for heavily contaminated or high viscosity fluids, or even if the temperature difference between the hot and cold medium is only minimal.

# Gasketed Plate Heat Exchangers

## Hxxx-LIQUID

## Operating data

Plate material	Stainless steel 1.4401 (AISI 316), 1.4306 (AISI 304) SMO Titanium
Plate thickness	0.4 – 0.6 mm
Seals	NBR (HT) EPDM Viton
Connections	Threaded pipe, male Flange (up to DN300) Note: The connection interface can only be altered before manufacture.
Paint colour	RAL 5010 Corrosion class: C2L Other paint finishes on request
Media	Hydraulic oil, lubrication oil, rolling oil, engine oil HFC, HFA, HFD, operating fluids water, water-glycol, seawater (with titanium plates) Limited possibility: steam applications
Operating temperature	up to 140 °C
Pressure ranges	10 bar, 16 bar, 25 bar Note: Pressure surges must be avoided
Flow rate	up to 2,000 m³/h
Cooling capacity	up to 30,000 kW (dependent on the inlet temperature of the media and the flow rate)
Contamination	The level of particles in suspension should be less than 10 mg/l Particle size: <0.6 mm (spherical); thread-like particles cause a rapid rise in pressure drop.
Water quality	See table on water quality
Options	Safety heat exchanger Dual unit with change-over valve Insulation

Depending on the individual situation, special models using higher grade materials are available, e.g. titanium plates are used for seawater applications.

## Area of application

Cooling circuits in counterflow which are operated using water, coolant, HFC operating fluids or oil. For applications using other fluids please contact the specialist department.

Typical applications are:

- Hydraulic systems
- Presses
- Lubrication systems
- Test rigs
- Motors/engines

## Model Code

**H-38 - IG 10 - 12 - TKTM33 - LIQUID**

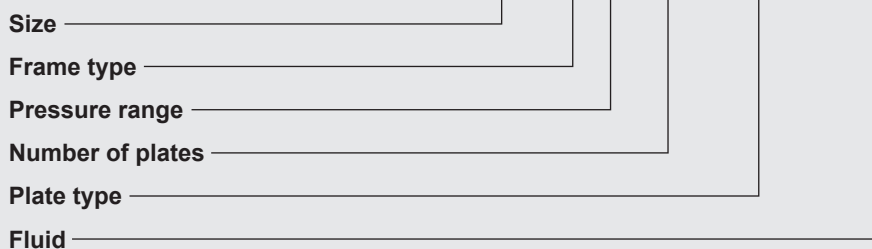

## Water quality

Substances dissolved in water	Concentration of substance in mg/l	Notes below relate to 1.4401
Aluminium (Al) – in solution	<0.2	A
	>0.2	A
Ammonia NH <sub>3</sub>	<2	A
	2 – 20	A
	>20	A
Chloride Cl <sup>-</sup> (max. +60 °C)	<250	A
	>250	B
Electrical conductivity	<10 µ S/cm	A
	10 – 500 µ S/cm	A
	>500 µ S/cm	A
Iron Fe – in solution	<0.2	A
	>0.2	A
Free aggressive carbonic acid CO <sub>2</sub>	<5	A
	5 – 20	A
	>20	A
Total hardness	4.0 – 8.5 °dH	A
Glycol percentage	<20 %	A
	20 – 50 %	A
	>50 %	A
HCO <sub>3</sub> <sup>-</sup> SO <sub>4</sub> <sup>-2</sup>	<1.0	A
	>1.0	A
Hydrogen carbonate HCO <sub>3</sub> <sup>-</sup>	<70	A
	70 – 300	A
	>300	A
Manganese Mn – in solution	<0.1	A
	>0.1	A
Nitrate – in solution NO <sub>3</sub>	<100	A
	>100	A
pH value	<6	B
	6.0 – 7.5	A / B
	7.5 – 9.0	A
	>9	A
Sulphate SO <sub>4</sub> <sup>-2</sup>	<70	A
	70 – 300	A
	>300	C
Sulphite SO <sub>3</sub> / Free chlorine gas Cl <sub>2</sub>	<1	A
	1 – 5	A
	>5	A / B
Hydrogen sulphide (H <sub>2</sub> S)	<0.05	A
	>0.05	A

A = under normal circumstances, good resistance  
 B = danger of corrosion, especially if several B substances are present  
 C = not suitable

Chloride content	Max. wall surface temperature			
	60 °C	80 °C	120 °C	130 °C
≤10 ppm	W 1.4301	W 1.4301	W 1.4301	W 1.4401
≤25 ppm	W 1.4301	W 1.4301	W 1.4401	W 1.4401
≤50 ppm	W 1.4301	W 1.4401	W 1.4401	Ti
≤80 ppm	W 1.4401	W 1.4401	W 1.4401	Ti
≤150 ppm	W 1.4401	W 1.4401	Ti	Ti
≤300 ppm	W 1.4401	Ti	Ti	Ti
>300 ppm	Ti	Ti	Ti	Ti

Note: This table is not exhaustive and serves only as a guide.

## Dimensions

The dimensions can vary according to the frame type. Gasketed plate heat exchangers are calculated individually according to the application. You will find the relevant frame length L on the data sheet for your calculation.

### H8 / H16

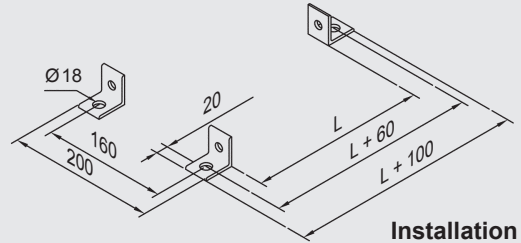
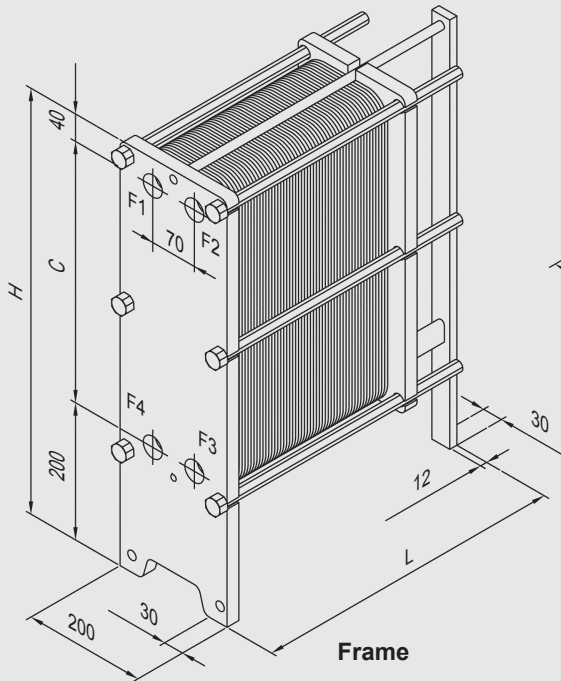

Installation

Pressure ranges: 16 bar, 25 bar

Size	Dimension H	Dimension C
H8	621 mm	381 mm
H16	896 mm	656 mm

### H14 / H28 / H40

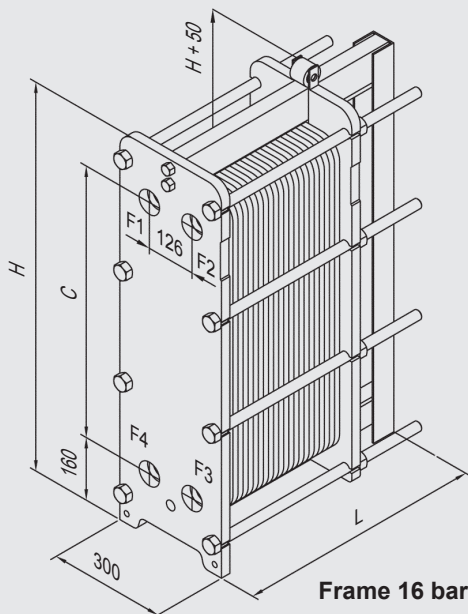

Frame 16 bar

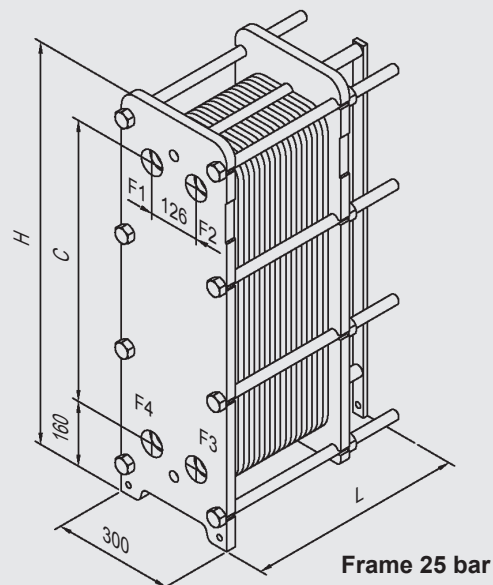

Frame 25 bar

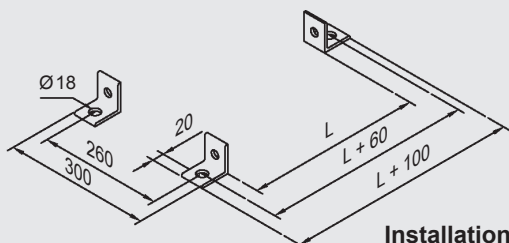

Installation

Pressure ranges: 16 bar, 25 bar

Size	Dimension H	Dimension C
H14	694 mm	394 mm
H28	994 mm	694 mm
H40	1,194 mm	894 mm

## H18 / H38 / H62

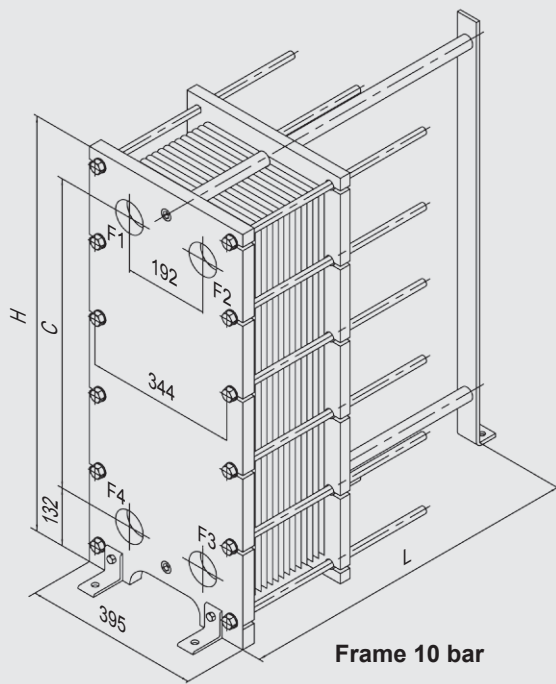

Frame 10 bar

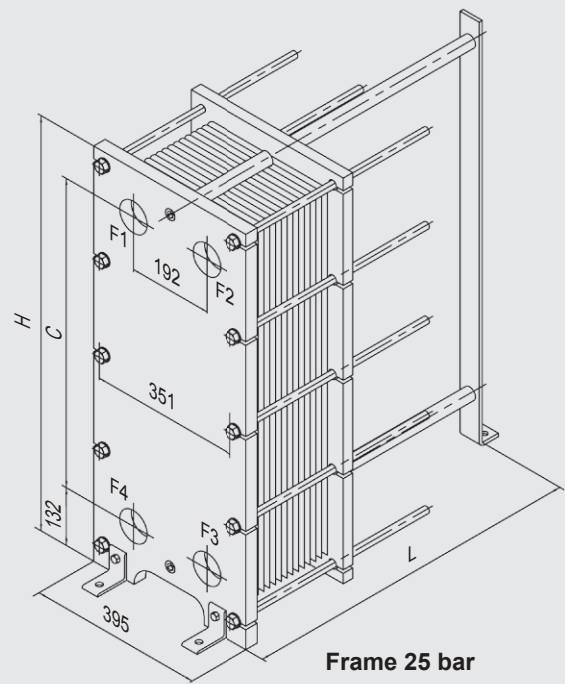

Frame 25 bar

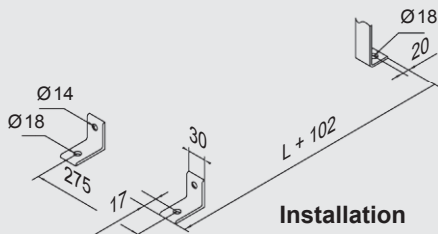

Installation

Pressure ranges: 10 bar, 16 bar

Size	Dimension H	Dimension C
H18	626 mm	380 mm
H38	946 mm	700 mm
H62	1,296 mm	1,050 mm

## H42 / H44 / H94 / H128

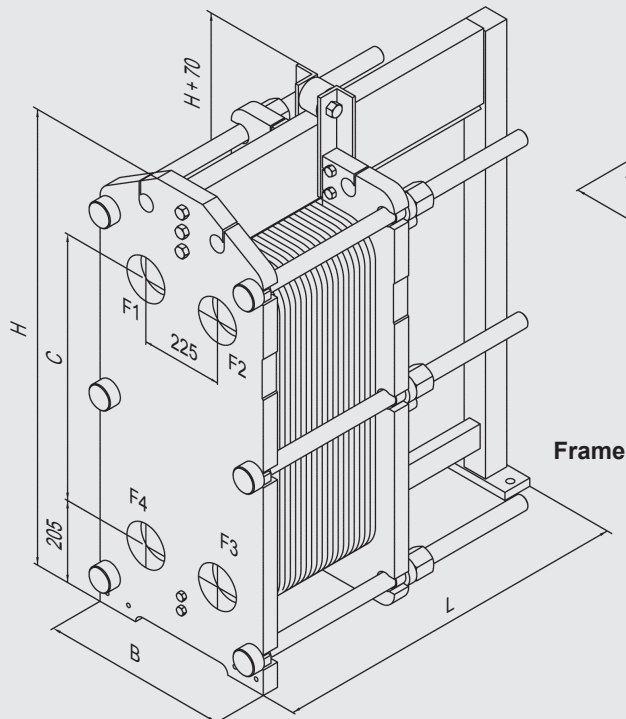

Frame

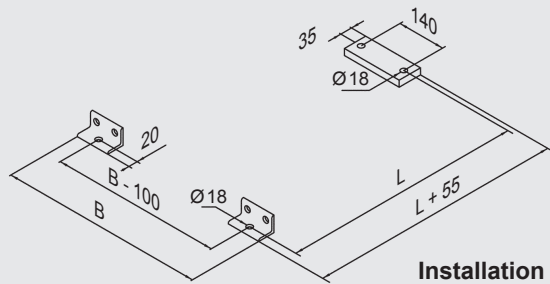

Installation

Pressure ranges: 10 bar, 16 bar, 25 bar

Size	Dimension H	Dimension C	Dimension B
H42 / H44	1,238 mm	719 mm	495 mm
H94	1,884 mm	1,365 mm	480 mm
H128	2,291 mm	1,771 mm	480 mm

## H47 / H102

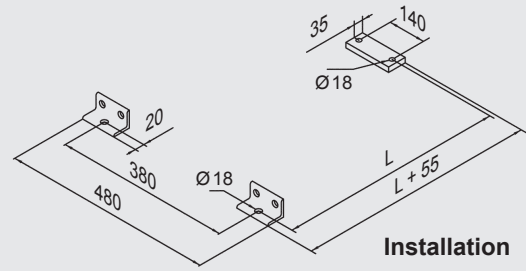
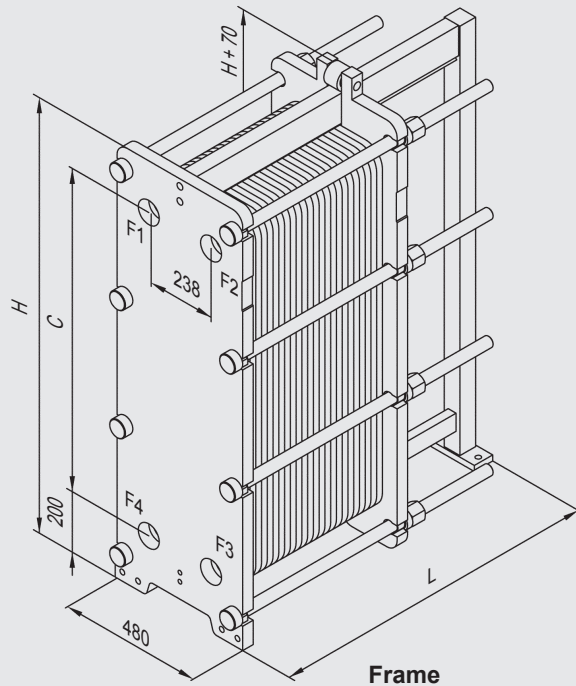

Pressure ranges: 10 bar, 16 bar

Size	Dimension H	Dimension C
H74	1,441 mm	1,070 mm
H102	1,855 mm	1,484 mm

## H82 / H84 / H124 / H172 / H220

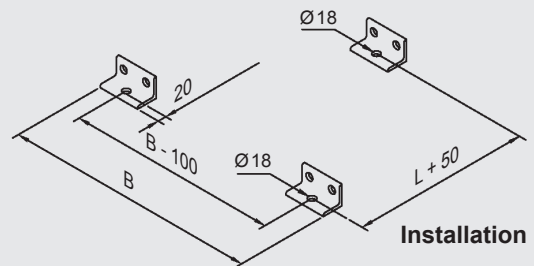
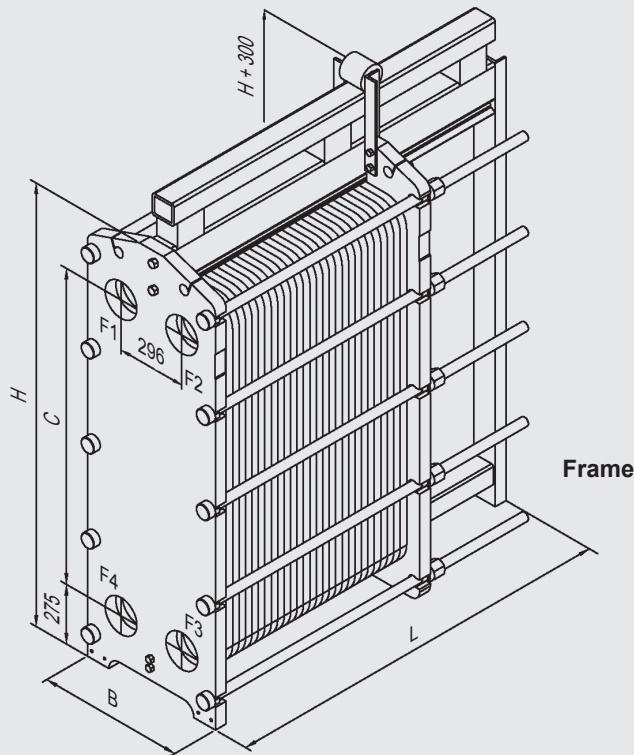

Pressure ranges: 10 bar, 16 bar, 25 bar

Size	Dimension H	Dimension C	Dimension B 10, 16 bar	Dimension B 25 bar
H82 / H84	1,450 mm	890 mm	608 mm	640 mm
H124	1,852 mm	1,292 mm	608 mm	640 mm
H172	2,254 mm	1,694 mm	608 mm	640 mm
H220	2,654 mm	2,094 mm	608 mm	640 mm



## Note

The information in this brochure relates to the operating conditions and applications described.

For applications and operating conditions not described, please contact the relevant technical department.

Subject to technical modifications.

**HYDAC**

HYDAC COOLING GMBH

**INTERNATIONAL**

Industriegebiet  
66280 Sulzbach/Saar  
Germany

Tel.: +49 6897 509-01  
Fax: +49 6897 509-454

E-mail: [cooling@hydac.com](mailto:cooling@hydac.com)  
Internet: [www.hydac.com](http://www.hydac.com)