

Safety and Shut-off Block

SAF/DSV

1. DESCRIPTION

1.1. GENERAL

The HYDAC safety and shut-off block is used to shut off and discharge hydraulic accumulators or user units. It complies with the relevant safety standards in accordance with DIN EN 982 and the German industrial safety regulations, BetrSichV.

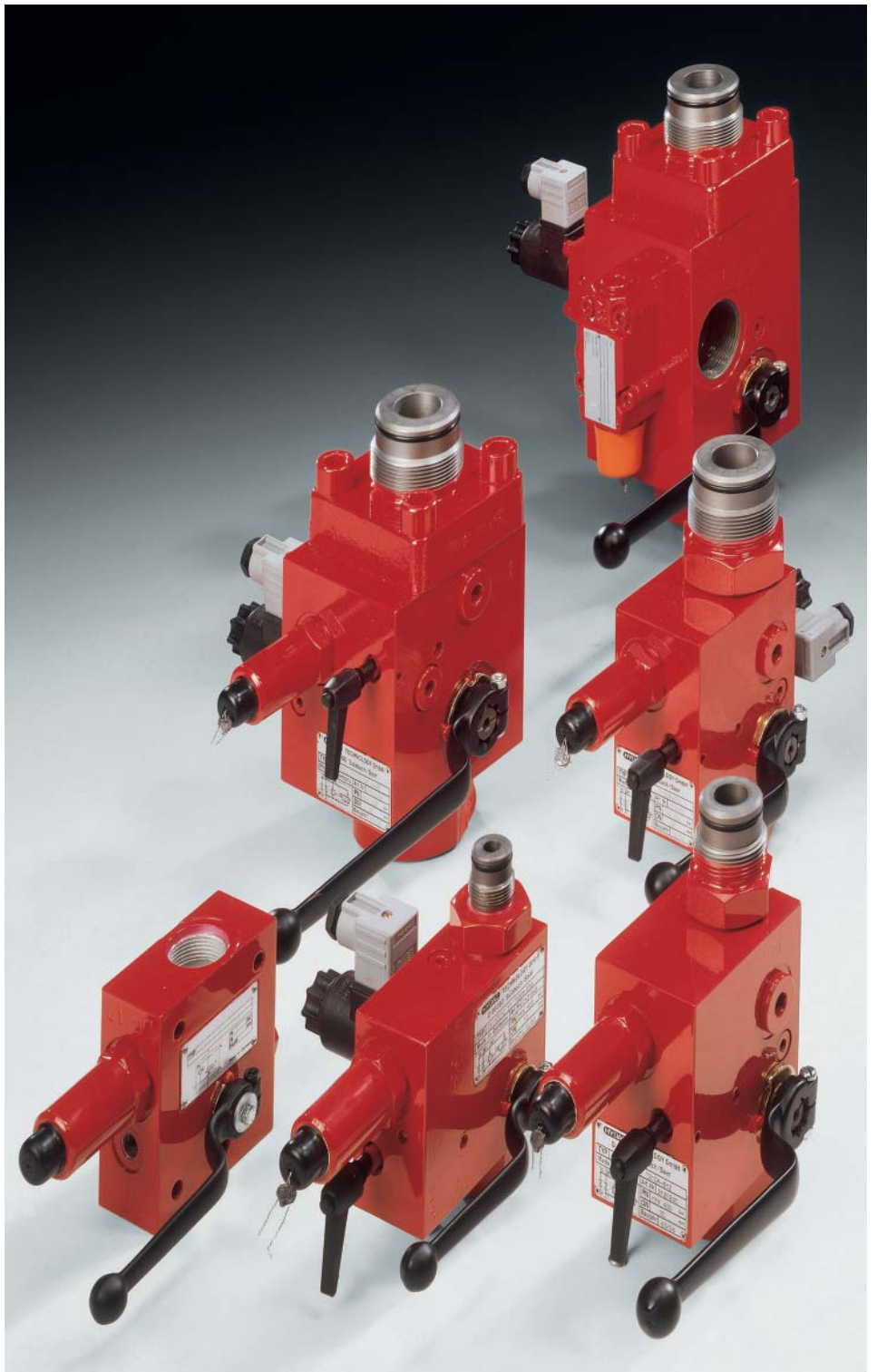

HYDAC SAFETY AND SHUT-OFF BLOCK

INDEX	Page
1. DESCRIPTION OF SAF	1-4
1.1. GENERAL	1
1.2. CONSTRUCTION	3
1.3. CONNECTIONS	3
1.4. TECHNICAL SPECIFICATIONS	3
1.5. STANDARD MODELS	3
1.6. GRAPHS FOR SAF	4
2. MODEL CODE FOR SAF	5
3. DIMENSIONS OF SAF	6-8
3.1. TYPE SAF 10	6
3.2. TYPE SAF 20	7
3.3. TYPE SAF 32	8
4. SPARE PARTS FOR SAF	9
5. DESCRIPTION OF DSV 10	10-13
5.1. GENERAL	10
5.2. CONSTRUCTION	10
5.3. PORTS	10
5.4. FUNCTION	10
5.5. NOTES	10
5.6. TECHNICAL SPECIFICATIONS	11
5.7. SPARE PARTS	11
5.8. MODEL CODE FOR DSV 10	12
5.9. DIMENSIONS	13
6. ACCESSORIES	14-16
6.1. ADAPTORS	14-16
6.2. SHUT-OFF VALVES	16
7. SPECIAL MODELS	17-21
7.1. TYPE SA 32 M (E) 28	17
7.2. TYPE SA 32 M (E) 29	18-19
7.3. SA BLOCK WITH ADDITIONAL EQUIPMENT	20
7.4. SA BLOCK FOR HIGH FLOW RATE	21
7.5. SA BLOCK FOR FRONT PANEL MOUNTING	21
7.6. SA BLOCK WITH 2-WAY CARTRIDGE VALVE (LOGIC ELEMENT)	21
8. NOTE	21

1.1.1 Key to circuit diagram

- ① Safety valve to prevent excess pressure to PED 97/23/EC

The Hydac pressure relief valve DB12 is used on the SAF series. This is a direct-operated pressure relief valve in seat valve construction with excellent opening and closing properties. This version of DB 12 valve conforms to the requirements of the Pressure Equipment Directive 97/23/EC with CE marking.

- ② Pressure gauge
 ③ Shut-off valve
 ④ Pressure release valve
 ⑤ Connection for test gauge

These devices are combined in a compact, space-saving HYDAC safety and shut-off block. The following devices are also available:

- ⑥ Solenoid-operated pressure release valve.
 ⑦ Throttle

1.1.2 Product benefits

The compact combination of elements considerably simplifies the connection of an accumulator or user unit to the hydraulic system and provides the following advantages:

- Minimum of space, maintenance and installation required. As all the individual units are combined in one block, considerably fewer pipe fittings are necessary for installation.
- Considerable reduction in installation time
- All types of connections for all accumulator systems and makes are available - imperial and metric connections as well as manifold mounted and weld nipple connections.
- Additional valves such as pilot-operated check valves, flow control valves and combined flow control and check valves can be fitted to the system connection P.



Circuit diagram

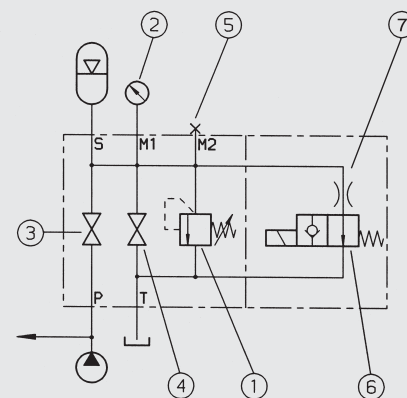

DB 12 CE p-Q graph, see ① above

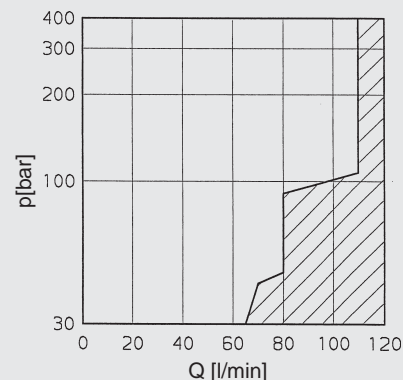

This valve cannot be set to values in the shaded area.

1.2. CONSTRUCTION

The SAF safety and shut-off block consists of a valve block, a built-in HYDAC pressure relief valve, a main shut-off valve and a manually operated pressure release valve, and the necessary gauge connections are provided in addition to the tank connection. In addition an optional solenoid-operated 2-way directional valve allows automatic pressure relief of the accumulator or user unit and therefore of the hydraulic system in an emergency or during shut-down.

1.3. CONNECTIONS

The safety and shut-off block has the following connections:

- S – Accumulator connection
- P – Pipe connection (pump)
- T – Tank connection
- M1 – Test gauge connection
G ½ - ISO 228
(G ¼ for SAF 10)
- M2 – Gauge connection
G ¼ - ISO 228

1.4. TECHNICAL SPECIFICATIONS

1.4.1 Operating fluids

Mineral oil to DIN 51524
Part 1 and 2
(other fluids on request)

VISCOSITY RANGE

min. 10 mm²/s
max. 380 mm²/s

FILTRATION

Max. permissible contamination level of the operating fluid to NAS 1638 class 10.

We therefore recommend a filter with a minimum retention rate of $\beta_{20} \geq 100$.

The fitting of filters and regular replacement of filter elements guarantees correct operation, reduces wear and tear and extends the service life.

1.4.2 Permissible working temperature

-10 °C to +80 °C
(ambient temperature on "E"
version limited to
-10 °C to +40 °C)

1.4.3 Max. operating pressure

400 bar

1.4.4 Model with solenoid-operated pressure relief

TYPE OF OPERATION

Solenoid-operated by means of pressure-tight, oil-immersed, single stroke solenoids in accordance with VDE 0580.

Actuating solenoid with plug to DIN 43650, standard for general industrial applications, available for 24 V DC and 230 V AC.

TYPE OF VOLTAGE

DC solenoid

When connected to AC voltage, the necessary DC voltage is produced by means of a bridge rectifier connector.

VOLTAGE TOLERANCE

-5 % to +10 %

NOMINAL CURRENT

Depending on the nominal voltage

24 V DC 1.04 A

230 V AC 0.13 A

POWER CONSUMPTION

$p_{20} = 26 \text{ W}$

SWITCH-ON TIME

100 % = continuous operation

SWITCHING TIME

Depending on symbol, pressure across the individual ports and flow rate,

switch-on time = approx. 25 ms,

switch-off time = approx. 35 ms

1.5. STANDARD MODELS

1.5.1 Model with manually operated pressure release valve

The basic model Safety and Shut-off Block has a manually operated pressure release valve, code "M", and a direct-operated pressure relief valve.

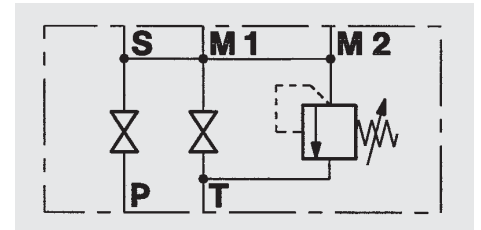

Sizes: SAF 10 M
SAF 20 M
SAF 32 M

1.5.2 Model with solenoid-operated pressure relief

The "E" model Safety and Shut-off Block contains a solenoid-operated 2-way directional valve (open when de-energised) (standard) for automatic pressure relief of the accumulator and the hydraulic system.

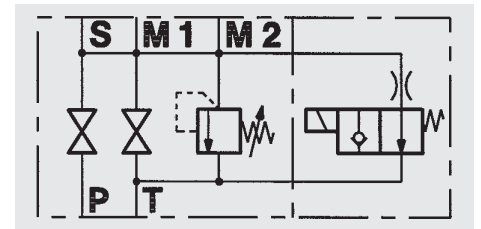

Sizes: SAF 10 E
SAF 20 E
SAF 32 E

1.6. Δp -Q GRAPHS FOR SAF
with DB 12 pressure relief valve

1.6.1 Flow from the pump to the accumulator

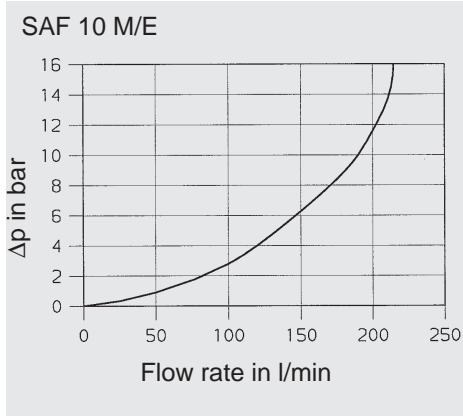

1.6.2 Flow from the accumulator via the solenoid-operated pressure release valve to the tank

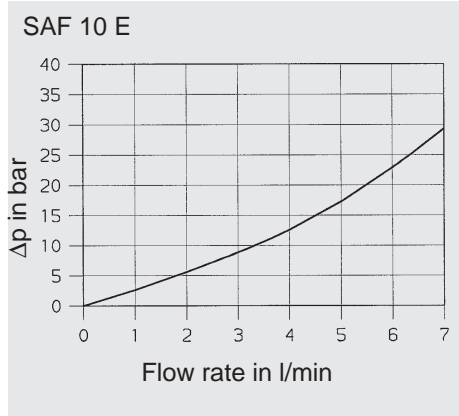

1.6.3 Flow from the accumulator via the pressure release valve to the tank

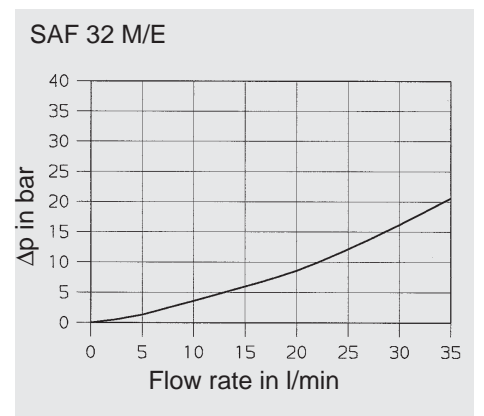
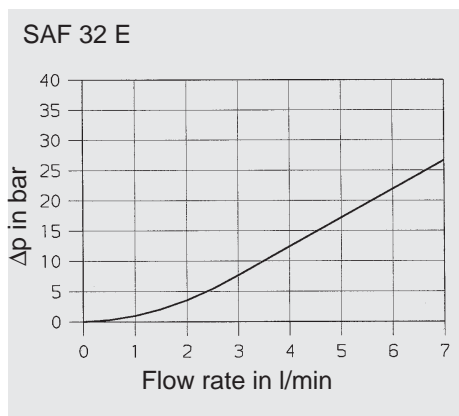
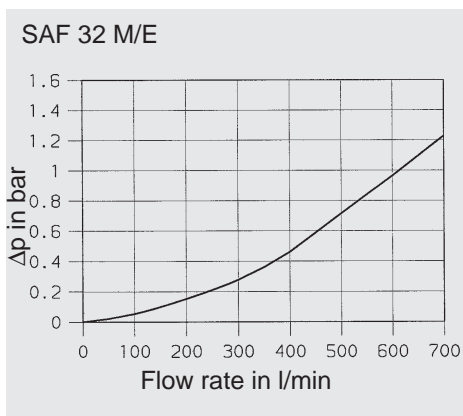
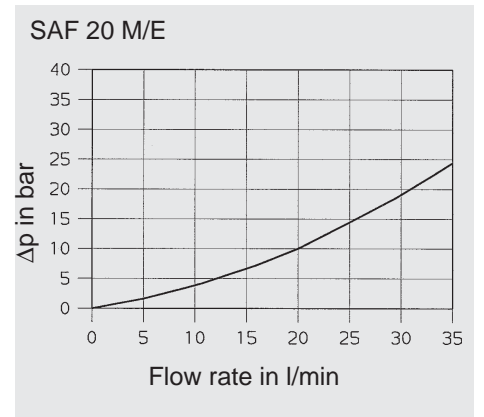
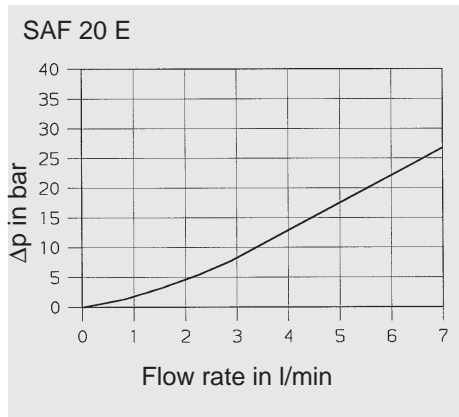
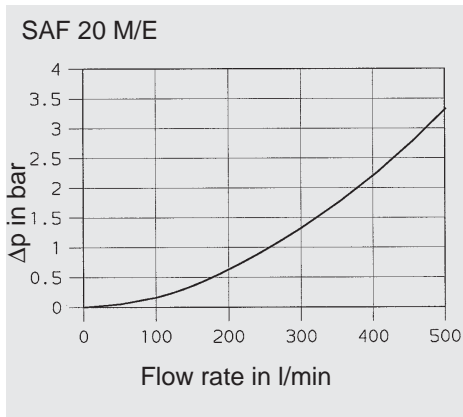
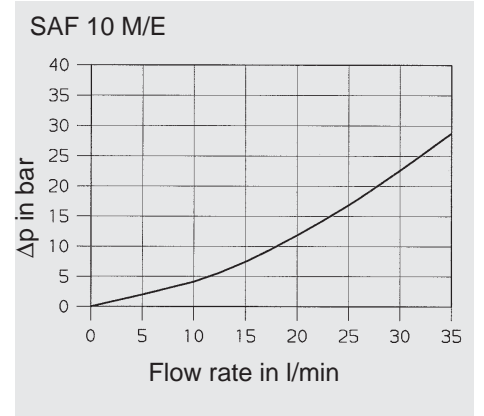

measured at:
 $v = 32 \text{ mm}^2/\text{s}$
 $t_{oil} = 40 \text{ }^\circ\text{C}$
 operating pressure = 400 bar

2. MODEL CODE FOR SAF

(also order example)

SAF 20 E 1 2 Y 1 T 210 A -S 13 -LPI

Safety and shut-off block

Series SAF

Size of main shut-off valve

- 10 = DN 10
- 20 = DN 20
- 32 = DN 32

Discharge

- M = Manual discharge
- E = Solenoid-operated and manual discharge

Block material

- 1 = Carbon steel
- 2 = 1.4021 (stainless steel 304)
- 3 = 1.4571 (stainless steel 316)
- 7 = Other

Seal material (elastomer)

- 2 = NBR (Perbunan)
- 5 = EPDM
- 6 = FPM (Viton)
- 7 = Other

For solenoid-operated discharge with manual override

- Y = Open when de-energised (2-way directional valve 2SV5E2Y)
- Z = Closed when de-energised (2-way directional valve 2SV5E2Z)

Type of voltage – seat valve

- 1 = 24 V DC
- 2 = 110 - 115 V AC
- 3 = 220 - 230 V AC
- 6 = 120 V AC
- 7 = Other

Pressure relief valve

- T... = Pressure-set and lead-sealed by TÜV
- N... = Adjustable using Allen key 1)

Pressure setting

e.g. 210 bar

Threaded connections to

- A = ISO 228 (BSP)
- B = DIN 13, to ISO 965/1 (metric)¹⁾
- C = ANSI B1.1 (UNF, O-ring seal to SAE)¹⁾
without M2-gauge connection

Adaptor

to accumulator (see point 6.1.)
e.g. S13 = ISO 228 - G 2A

Additional equipment (see Point 7.3)

- L = lockable main shut-off valve (for use with padlock)
- LPI = model L with additional position monitoring (inductive proximity switch)
- LPM = model L with additional position monitoring (mechanical limit switch)

Accessories

(When ordering please give full details) e.g. Shut-off valve for pressure gauges
(see point 6.2.)

¹⁾ on request

3. DIMENSIONS

3.1. SAF 10 SAFETY AND SHUT-OFF BLOCK SIZE 10

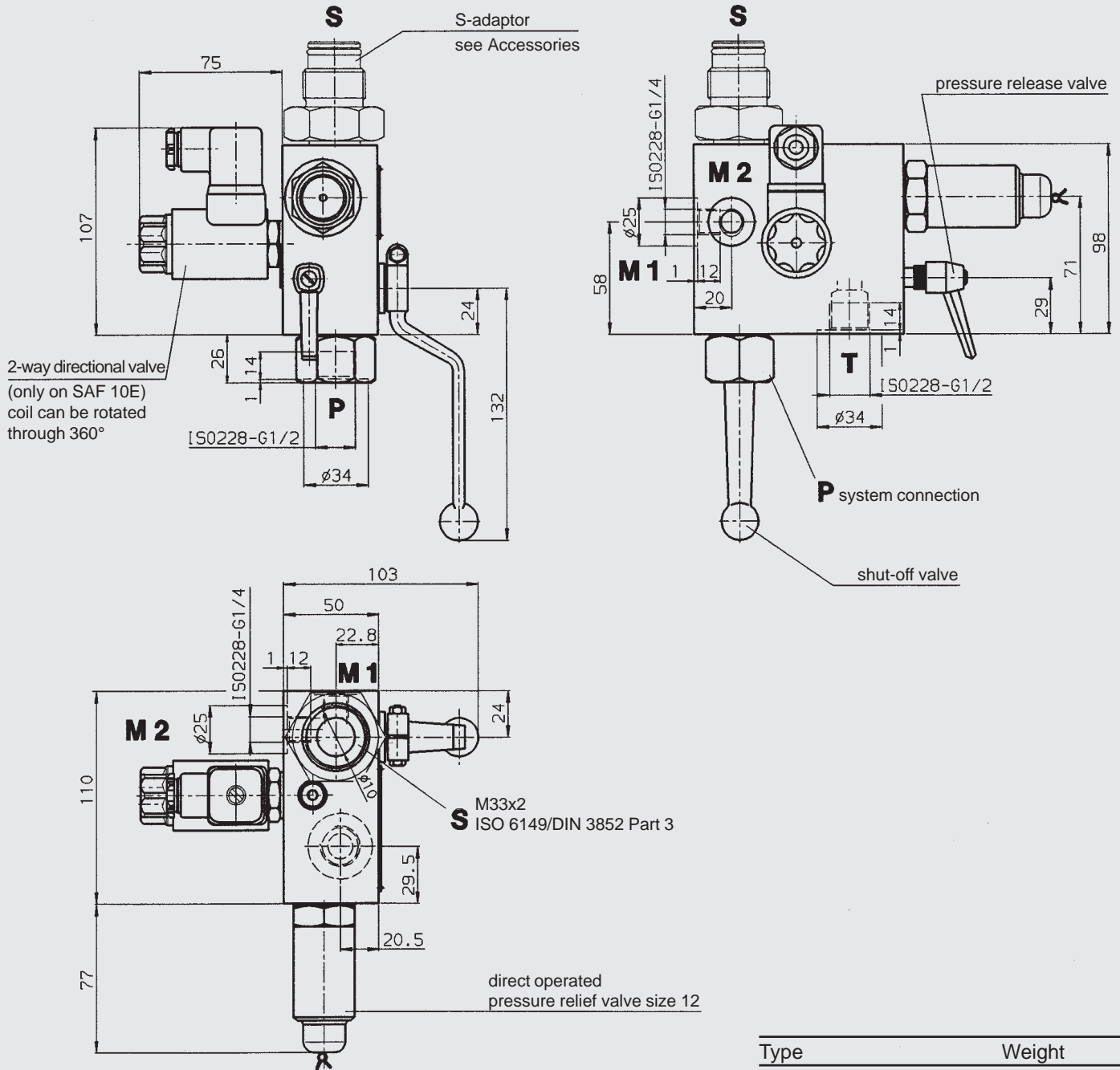

Type	Weight
SAF 10 M...	4.2 kg
SAF 10 E...	4.6 kg

SAF10 standard models

Model	Stock no.	Model	Stock no.
SAF10M12T400A	2121582	SAF10E12Y1T400A	2125858
SAF10M12T350A	2122208	SAF10E12Y1T350A	2122210
SAF10M12T330A	2121236	SAF10E12Y1T330A	2122211
SAF10M12T315A	2121121	SAF10E12Y1T315A	2122212
SAF10M12T300A	2121354	SAF10E12Y1T300A	2122213
SAF10M12T250A	2121353	SAF10E12Y1T250A	2122214
SAF10M12T210A	2121346	SAF10E12Y1T210A	2121662
SAF10M12T200A	2121351	SAF10E12Y1T200A	2122215
SAF10M12T150A	2121345	SAF10E12Y1T150A	2122216
SAF10M12T100A	2121344	SAF10E12Y1T100A	2122041
SAF10M12T070A	2121350	SAF10E12Y1T070A	2122217
SAF10M12T050A	2122207	SAF10E12Y1T050A	2122218
SAF10M12T035A	2121349	SAF10E12Y1T035A	2122219

4. SPARE PARTS FOR SAF

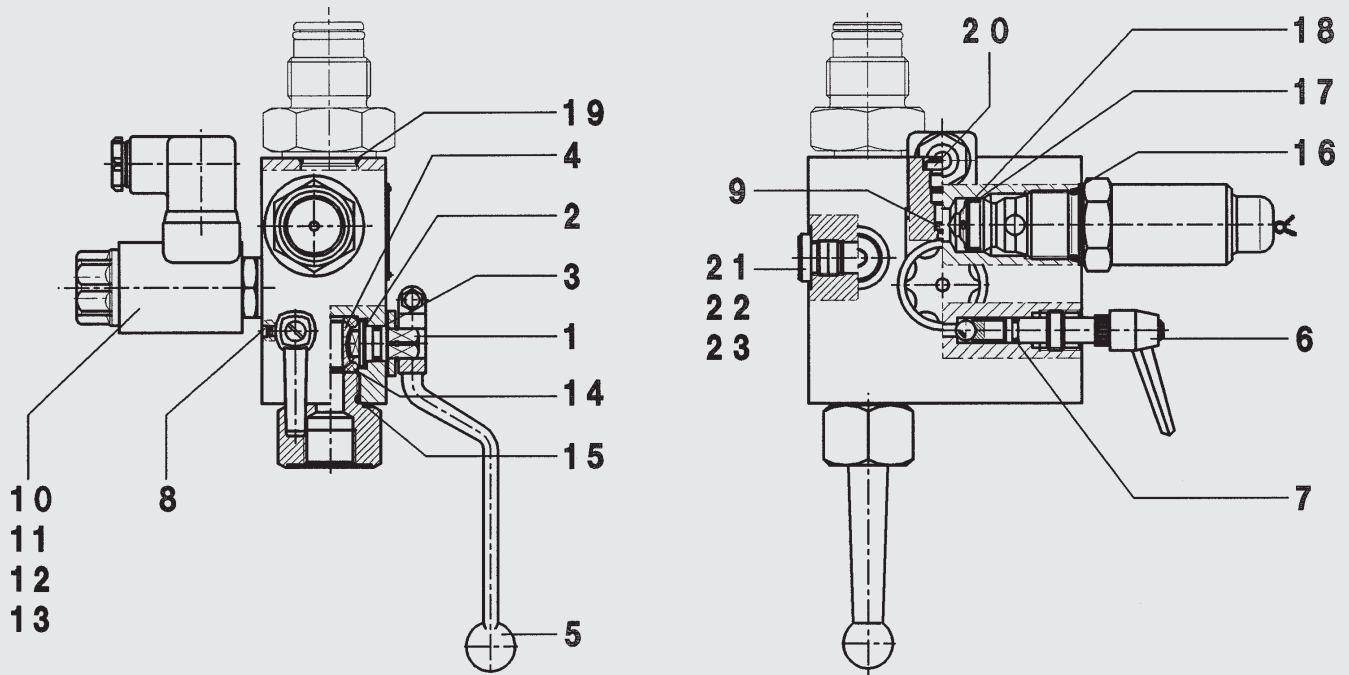

SAF block	SAF 10 M SAF 10 E	SAF 20 M SAF 20 E	SAF 32 M SAF 32 E
Description	Item	Dimensions	
Repair kit	Stock no.	Stock no.	Stock no.
consists of:	2122238 (NBR) 2122240 (FPM)	2122242 (NBR) 2122244 (FPM)	2122246 (NBR) 2122248 (FPM)
Spindle	1		
Disc	2		
O-ring	3	10 x 2	15 x 2.5
Ball	4		
Switching handle	5		
Spindle	6		
O-ring	7	6 x 2	
Set screw	8	M 4x6	M 4x10
Slip-in orifice	9		
O-ring	11	17 x 2	
Support ring	12	11.7 x 15 x 1	
O-ring	13	11 x 2	
Sealing cup	14		
O-ring	15	21 x 2	34 x 2.5
O-ring	16	23.47 x 2.62	
Support ring	17	18.3 x 21.5 x 1	
O-ring	18	18 x 2	
O-ring	19	29.7 x 2.8	37.2 x 3
Blanking plug	20	G 1/8	G 1/8
	21	G 1/4	G 1/4
	22	-	G 3/8
	23	-	G 1/2
2-way directional valve, complete (for "E" version only)	10	Stock no. 2115443 (2SV5E2Y-open when de-energised) 2117453 (2SV5E2Z-closed when de-energised) 277645	
Blanking plug, complete (converts "E" version to "M" version)			
Seal kit consists of: Items 3, 7, 8, 11, 12, 13, 14, 15, 16, 17, 18, 19, 20, 21, 22, 23		Stock no. 2121699 (NBR) 2121701 (FPM)	Stock no. 2121703 (NBR) 2121705 (FPM)
Spindle repair kit consists of items 6, 7, 8		Stock no. 2115648 (NBR) 2115649 (FPM)	Stock no. 2121707 (NBR) 2121709 (FPM)

5. DESCRIPTION OF DSV 10

5.1. GENERAL

DSV 10 as a low cost alternative to the SAF 10

The 3-way safety block DSV 10 is used to shut off and discharge hydraulic accumulators or user units. It complies with relevant safety standards in accordance with DIN EN 982 and the German industrial safety regulations, BetrSichV.

The HYDAC pressure relief valve DB 12 is used with the DSV series. This is a direct-operated pressure relief valve in seat valve construction with excellent opening and closing characteristics.

This version of DB 12 complies with the requirements of the Pressure Equipment Directive 97/23/EC with CE marking.

There are four different models:

- DSV 10 M
Manual discharge
Standard L-ball
- DSV 10 M - T-ball
Manual discharge
T-ball, accumulator drain
- DSV 10 EY
Manual / solenoid-operated
discharge
Open when de-energised
- DSV 10 EZ
Manual / solenoid-operated
discharge
Closed when de-energised

The essential difference compared to the SAF10 lies in the shut-off and discharge function of the DSV10. On request we can supply other models to cover nearly all applications, e.g. for aggressive media.

On request we can supply test certificates to EN 10204 and quality test certificates to DIN 55350, Part 18.

5.2. CONSTRUCTION

The DSV 3-way safety block consists of a valve block with a built-in Hydac pressure relief valve and a shut-off valve. It has ports for the pump, pressure gauge, tank and accumulator. In addition an optional solenoid-operated 2-way directional valve allows automatic discharge of the accumulator or user unit.

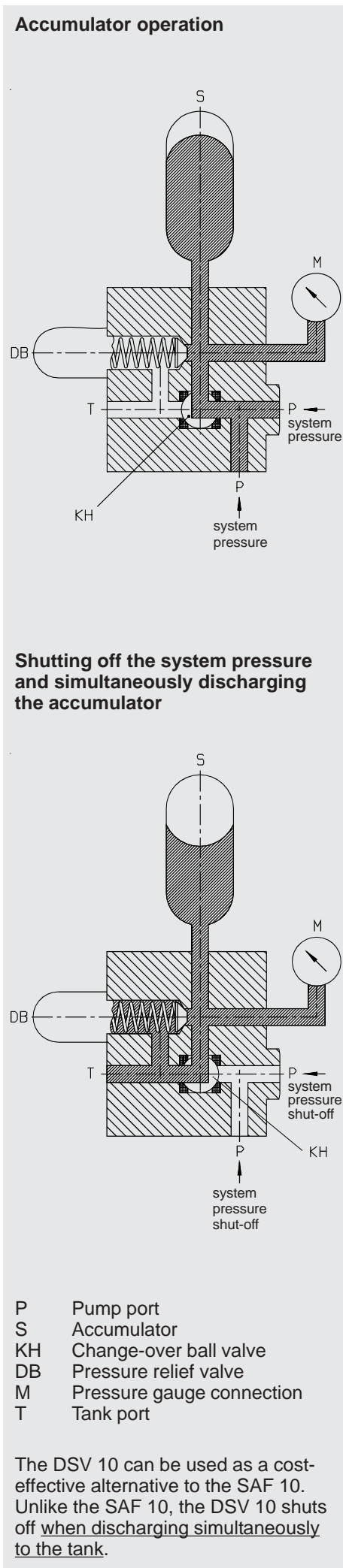

5.3. PORTS

The DSV has the following ports:

- S - Accumulator port
(M33x2 DIN 3852 Part 3)
- P - Inline port
(G 3/8 and G 1/2)
- T - Tank port
(G 1/4)
- M - Pressure gauge port
(G 1/4)

5.4. FUNCTION

When the accumulator is in operation the change-over ball valve connects the pump port with the accumulator. At the same time the accumulator is monitored for pressure via the built-in pressure relief valve.

By switching over the ball valve, the pump port is shut off leakage-free on the inlet side and the accumulator is discharged simultaneously to the tank.

During switching all three ports (P, S and T) are momentarily interconnected (negative switching overlap). If a solenoid-operated 2-way directional seat valve is fitted, automatic discharge is possible (e.g. in the event of a power failure or shut-down).

5.5. NOTES

Ball valves are not designed to be used as flow control valves; therefore they should always be either fully open or fully closed, to avoid damaging the sealing cups.

To ensure correct functioning, pressure and temperature specifications must be observed.

5.6. TECHNICAL SPECIFICATIONS

5.6.1 Symbols

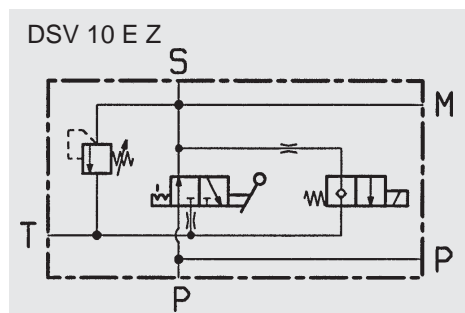
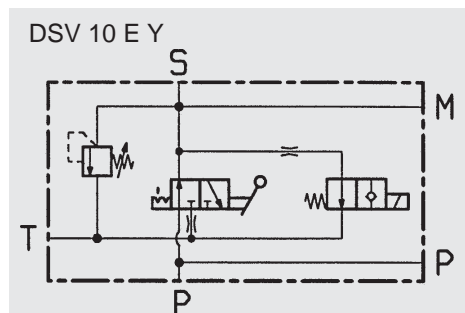
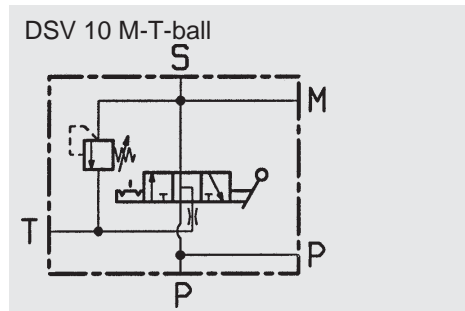
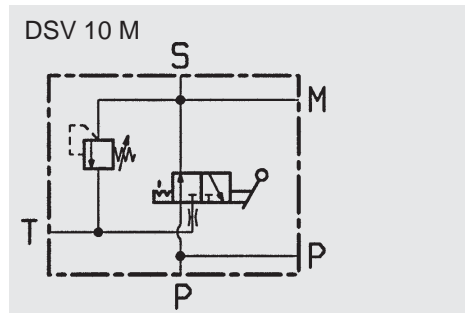

5.6.2 Type of construction

Ball valve isolating device

Pressure relief valve is direct-operated as a cone seat valve

Seat valve is pilot-operated

5.6.3 Materials

Housing and blanking plug in steel, surface protection: phosphate-plated

Ball in steel, hard-chromed

Pressure relief valve and seat valve in high tensile steel, closing element in hardened and polished steel, wear-resistant, surface protection: phosphate-plated

Ball seal in high quality synthetic material (POM)

Soft seals in Perbunan (NBR)

Clamped handle SW 09, cranked, in red anodised aluminium

5.6.4 Mounting position

Optional

5.6.5 Operating fluids

Mineral oil to DIN 51524, Part 1 and Part 2

(Other media on request)

VISCOSITY RANGE:

Min. 10 mm²/s

Max. 380 mm²/s

FILTRATION:

Max. permissible contamination level of the operating fluid to NAS 1638, Class 10.

We therefore recommend a filter with a minimum retention rate of $\beta_{20} \geq 100$.

The fitting of filters and the regular replacement of filter elements guarantees correct operation, reduces wear and tear and increases the service life.

5.6.6 Permissible operating temperature

-10 °C to +80 °C

(Ambient temperature for "E" version is limited to -10 °C to +40 °C)

5.6.7 Maximum operating pressure

350 bar

5.6.8 $\Delta p - Q$ graph

measured at

$t_{oil} = 50\text{ °C}$

$v = 30\text{ mm}^2/\text{s}$

Flow rate from P to S

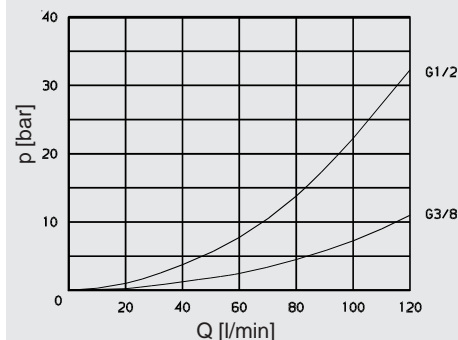

Flow rate from S to T

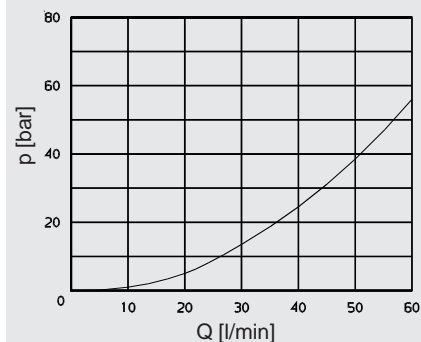

5.6.9 Model with solenoid-operated pressure relief

TYPE OF OPERATION

Solenoid-operated by means of pressure-tight, oil-immersed, single-stroke solenoids in accordance with VDE 0580.

Actuating solenoid with plug to DIN 43650, standard for general industrial applications, available for 24 V DC and 230 V AC.

TYPE OF VOLTAGE

DC solenoid

When connected to AC voltage the necessary DC voltage is produced by means of a bridge rectifier connector.

VOLTAGE TOLERANCE

-5 % to +10 %

NOMINAL CURRENT

Dependent on the nominal voltage

24 V DC 1.04 A

230 V AC 0.13 A

POWER CONSUMPTION

$p_{20} = 26\text{ W}$

SWITCH-ON TIME

100 % = continuous operation

SWITCHING TIME

Depending on symbol, pressure across the individual ports and flow rate,

switch-on time = approx. 25 ms

switch-off time = approx. 35 ms

5.7. SPARE PARTS

Please see brochure no. E 5.251, HYDAC DSV 3-way safety block.

5.8. MODEL CODE FOR DSV 10
(also order example)

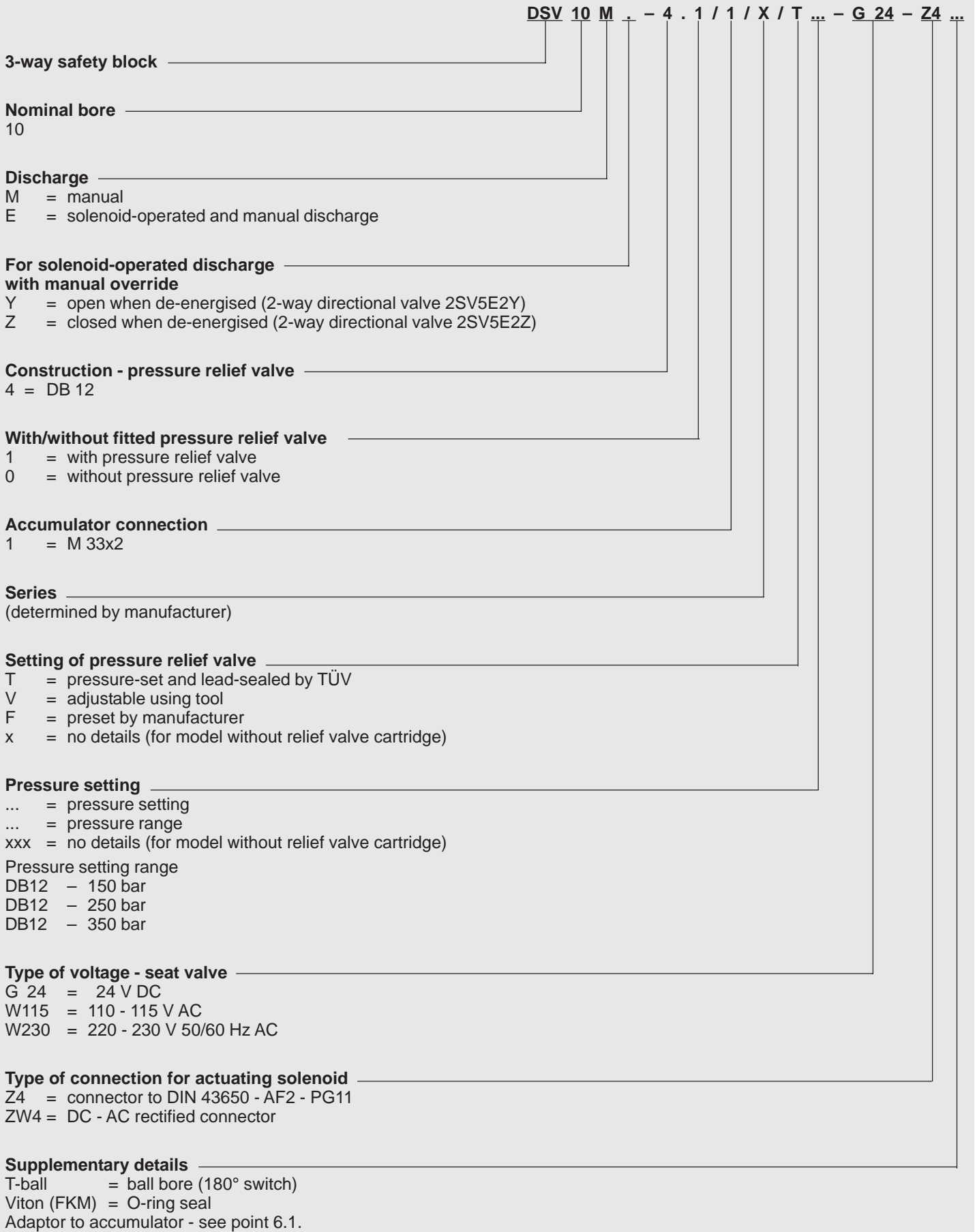

5.9. DIMENSIONS
DSV 10 3-way safety block

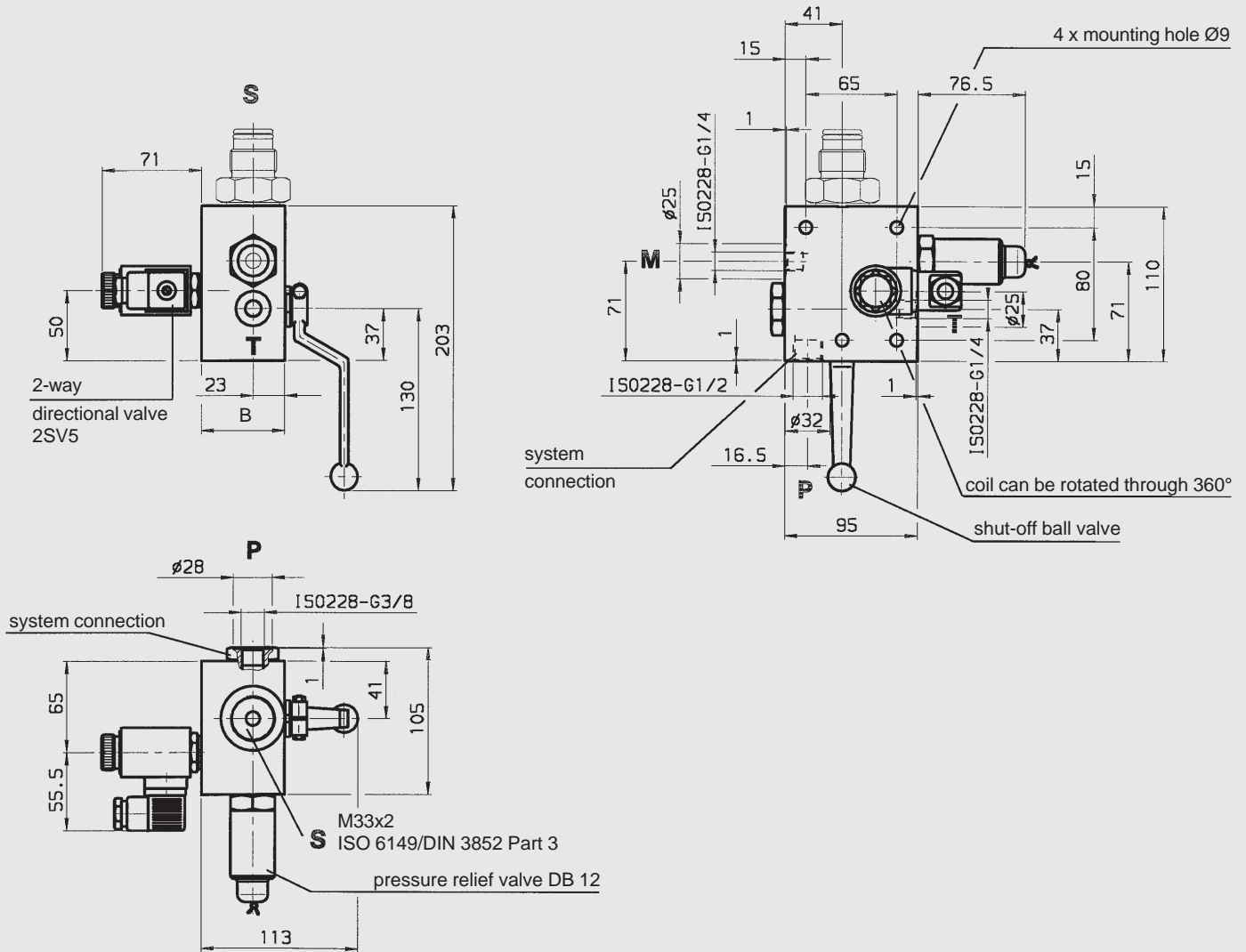

Type	B[mm]	Weight
DSV 10 M...	45	3.5 kg
DSV 10 E...	60	3.9 kg

DSV10 standard models

Model	Stock no.	Model	Stock no.
DSV-10-M-4.0/1/X/XXXX	555999	DSV-10-EY-4.0/1/X/XXXX-G24-Z4	557367
DSV-10-M-4.1/1/X/T035	555968	DSV-10-EY-4.1/1/X/T035-G24-Z4	555980
DSV-10-M-4.1/1/X/T050	555969	DSV-10-EY-4.1/1/X/T050-G24-Z4	555981
DSV-10-M-4.1/1/X/T070	555970	DSV-10-EY-4.1/1/X/T070-G24-Z4	555982
DSV-10-M-4.1/1/X/T100	555971	DSV-10-EY-4.1/1/X/T100-G24-Z4	555983
DSV-10-M-4.1/1/X/T150	555972	DSV-10-EY-4.1/1/X/T150-G24-Z4	555984
DSV-10-M-4.1/1/X/T200	555973	DSV-10-EY-4.1/1/X/T200-G24-Z4	555985
DSV-10-M-4.1/1/X/T210	555974	DSV-10-EY-4.1/1/X/T210-G24-Z4	555986
DSV-10-M-4.1/1/X/T250	555975	DSV-10-EY-4.1/1/X/T250-G24-Z4	555987
DSV-10-M-4.1/1/X/T300	555976	DSV-10-EY-4.1/1/X/T300-G24-Z4	555988
DSV-10-M-4.1/1/X/T315	555977	DSV-10-EY-4.1/1/X/T315-G24-Z4	555989
DSV-10-M-4.1/1/X/T330	555978	DSV-10-EY-4.1/1/X/T330-G24-Z4	555990
DSV-10-M-4.1/1/X/T350	555979	DSV-10-EY-4.1/1/X/T350-G24-Z4	555991

6. ACCESSORIES

6.1. ADAPTORS FOR SAF/DSV10

to connect the safety and shut-off block with the accumulator

6.1.1 Adaptor for standard bladder accumulator

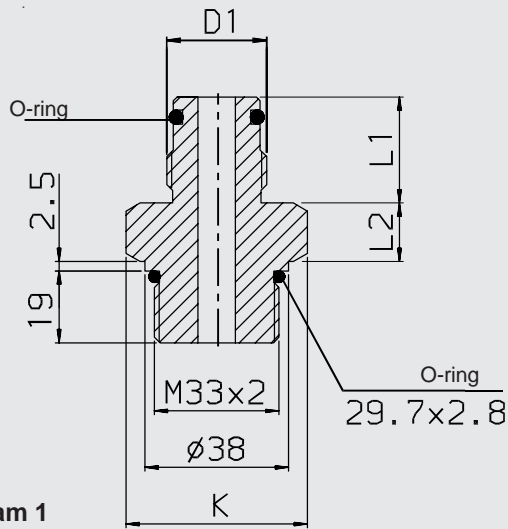

Diagram 1

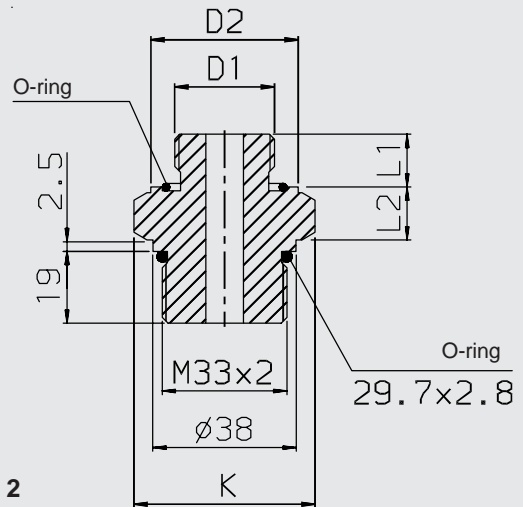

Diagram 2

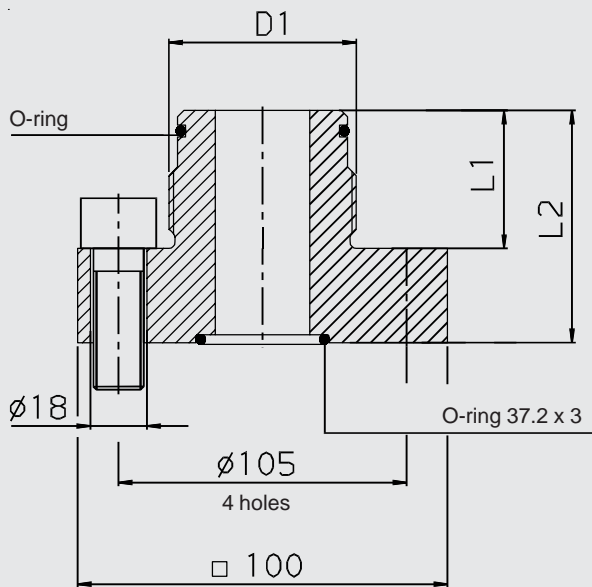

Diagram 3

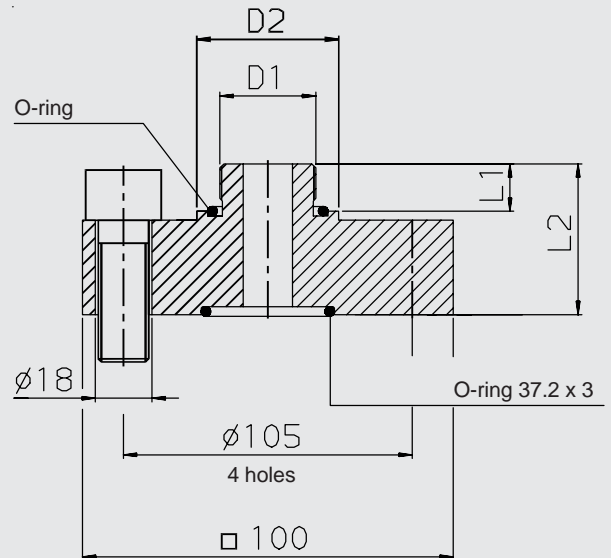

Diagram 4

Model	Accumulator type	D1 Thread	Adaptor	Stock no. ² NBR/C-steel	Diag. no.	K SW	L1 (mm)	L2 (mm)	D2 (mm)	O-ring
SAF 10/20 DSV 10	SB 330/400 - 0.5 to 1 l	G 3/4 A	S 10	369479	1	41	28	15.5		17x3
	SB 550/600 - 1 to 5 l	G 1 A	S 11	372750		46	34	16.5		22x3
	SB 330/400 - 2.5 to 5 l	G 1 1/4 A	S 12	369480			37		30x3	
	SB 330/400 - 10 to 50 l	G 2 A	S 13	369481		65	44	20.5		48x3
	SB 440/500/600 - 10 to 50 l									
	Connection with metric fine thread	M 30x1.5	S 20	369482	2	41	15	17.5	40	32x2
	M 40x1.5	S 21	369483	65		55	20	20.5	54	43x3
	M 50x1.5	S 22	369484			64			53x3	
SAF 32	SB 330/400 - 0.5 to 1 l	G 3/4 A	S 305 ¹	366723	3		28	58		17x3
	SB 550/600 - 1 to 5 l	G 1 A	S 306 ¹	2102855			34	64		22x3
	SB 330/400 - 2.5 to 5 l	G 1 1/4 A	S 307 ¹	366724			37	67		30x3
	SB 330/400/600 - 10 to 50 l	G 2 A	S 309 ¹	366715	4		44	74		48x3
	SB 440/500 - 10 to 50 l		S 308 ¹	376813			115			
	Connection with metric fine thread	M 30x1.5	S 330 ¹	366735	4		15	47	45	32x2
	M 40x1.5	S 340 ¹	366736	20			51	60	43x3	
	M 50x1.5	S 350 ¹	366737			75		53x3		

¹ Adaptor supplied with 4 off int. hex. screws M 16x45 (stock no. 615924). Tightening torque 175 Nm.

² Others on request

6.1.2 Adaptor for low pressure bladder accumulator

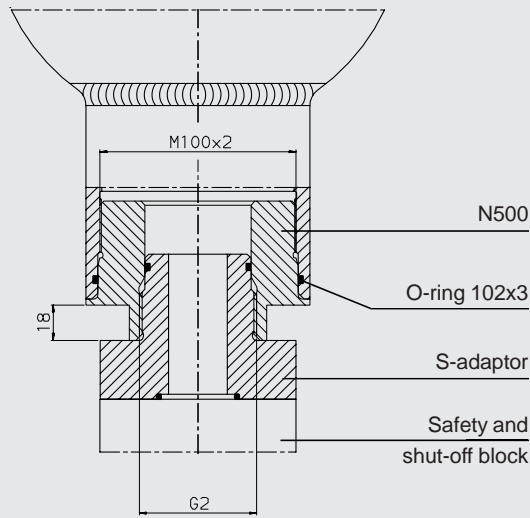

Model	Accumulator type	Adaptor	Stock no. ¹ NBR/C-steel	Corresponding S - adaptor	Stock no. ¹ NBR/C-steel
SAF 10/20 and DSV 10	SB40	N500	367229	S 13	369481
SAF 32	2.5 to 50 l	N500	367229	S 309	366715

6.1.3 Adaptor for diaphragm accumulator

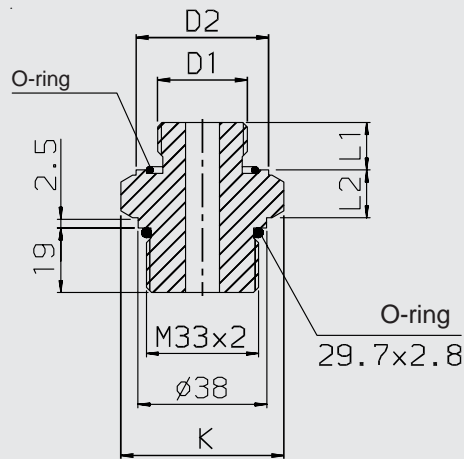

Model	Accumulator type	D1 Thread	Stock no. ¹ NBR/C-steel	Adaptor	K SW	L1 (mm)	L2 (mm)	D2 (mm)	O-ring
SAF10/20	SBO...E-0.075 to 1.4 l	G 1/2 A	369485	S 30	41	14	17.5	33	22x3
	SBO...A6-0.1 to 210-1.3 l								
DSV10	SBO...E-2.0 to 3.5 l	G 3/4 A	369486	S 31	41	16	17.5	40	28x3
	SBO...A6-400-1.3 to 4 l								

¹ Others on request

6.1.4 Adaptor for piston accumulator

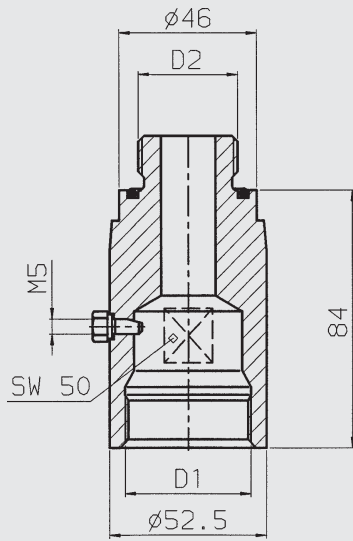

Diagram 5

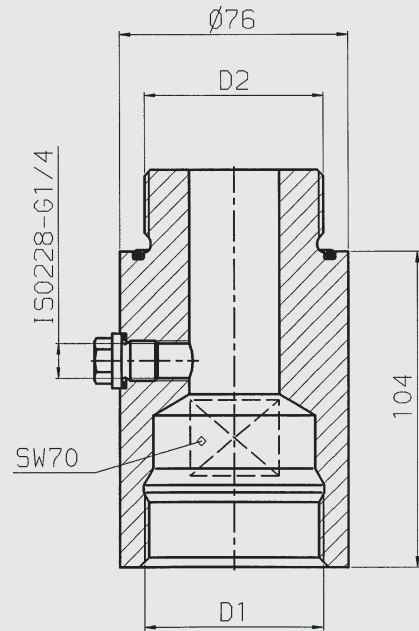
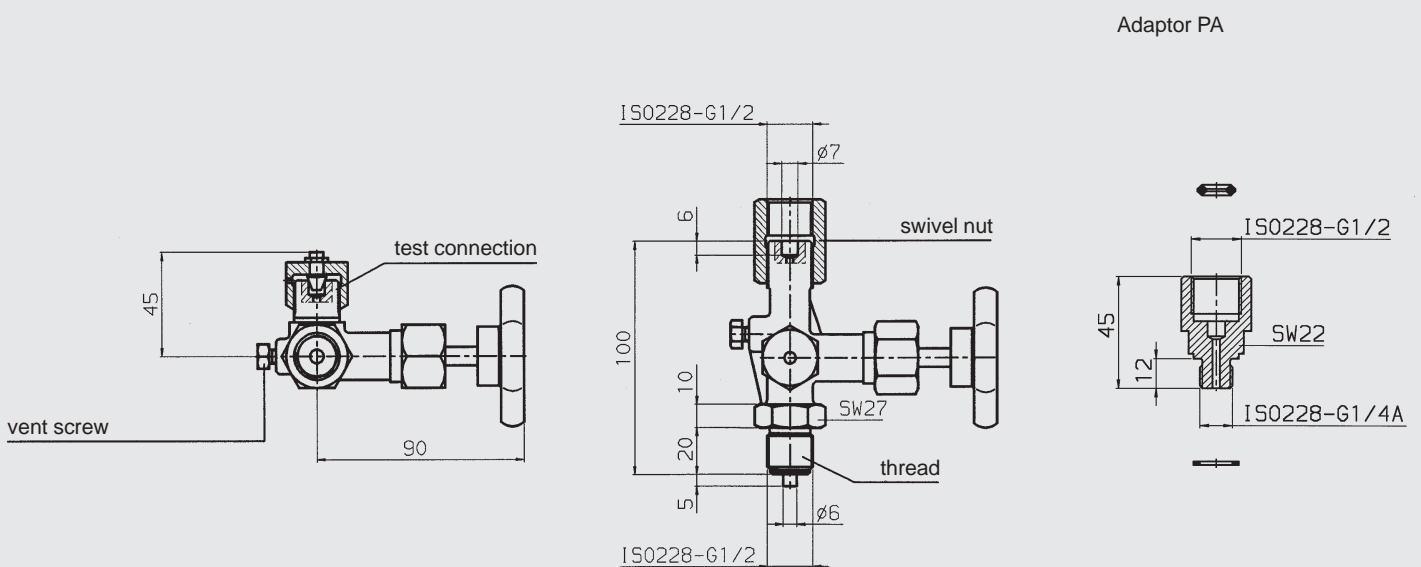

Diagram 6

Model	Accumulator type	Adaptor	Stock no. ¹ NBR/C-steel	Diag. no.	D1 (mm)	D2 (mm)	O-ring	Corresponding S-adaptor	Stock no. ¹ NBR/C-steel
SAF 10/20	SK210/350 - 2.5 to 7.5	K 406	374929	5	G 1 1/4	G 1	35x3	S 12	369480
DSV 10	SK210/350 - 10 to 45	K 408	374931	6	G 2	G 1 1/2	53x3	S 13	369481
SAF 32	SK210/350 - 50 to 120	K 409	374933			G 2	62x3	S 309	366715

¹ Others on request

6.2 SHUT-OFF VALVE FOR PRESSURE GAUGES



Consisting of shut-off valve AG (stock no. 611 903) with vent screw, swivel nut, thread and test connection to DIN 16271 as well as adaptor PA with seals (stock no. 370754).

7. SPECIAL MODELS

7.1. TYPE SA 32 M (E) 28

with direct operated pressure relief valve size 30
(max. working pressure 315 bar)

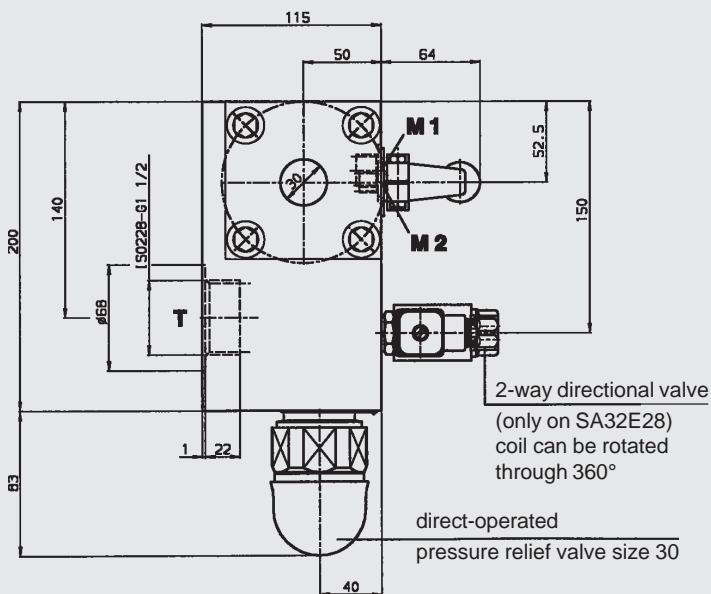
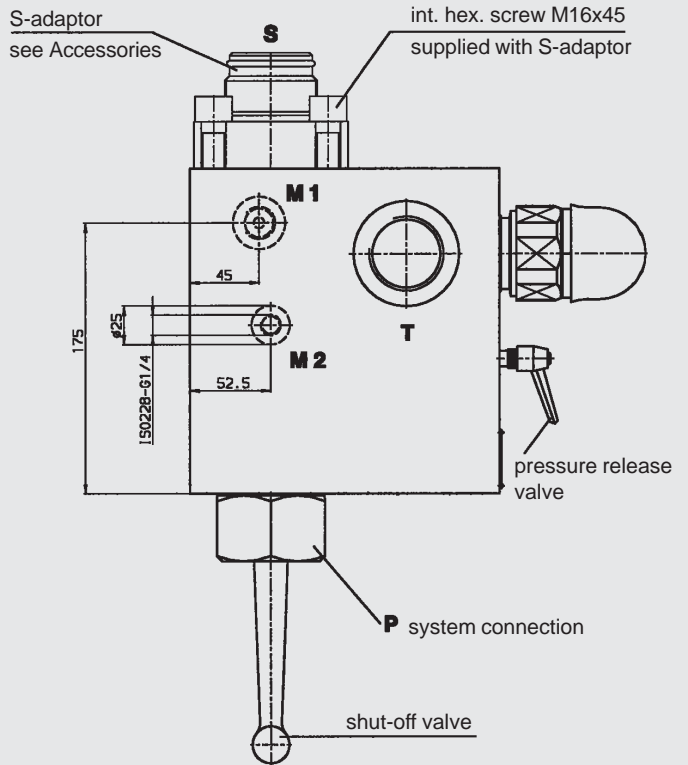
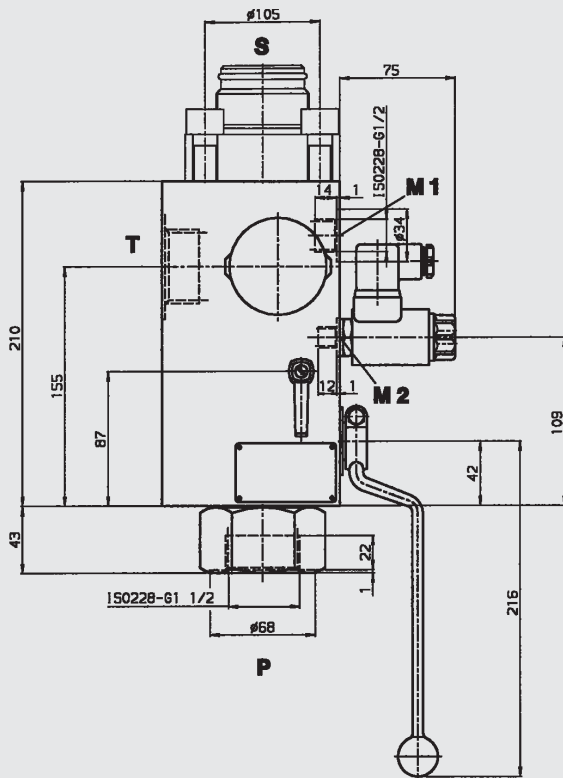

Direct-operated pressure relief valve size 30

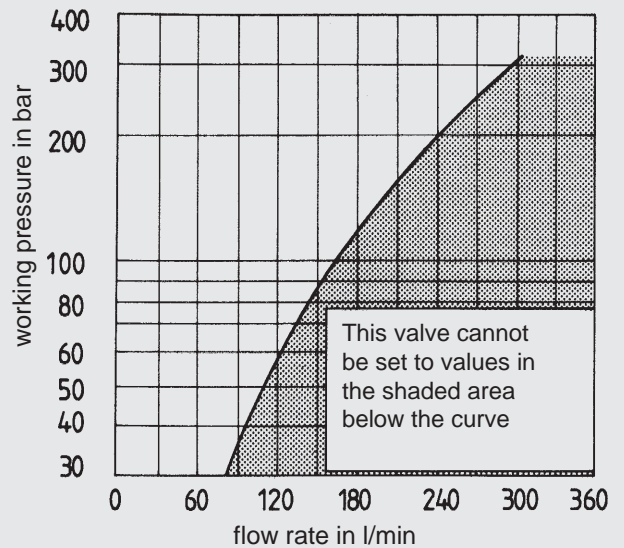

Two different models of the 2-way directional valve are available:

2SV5E2Y
(open when de-energised)

2SV5E2Z
(closed when de-energised)

Type	Weight
SA 32 M 28...	38 kg
SA 32 E 28...	39 kg

7.2 TYPE SA 32 M (E) 29
 with pilot-operated pressure relief valve
 (max. operating pressure 330 bar)

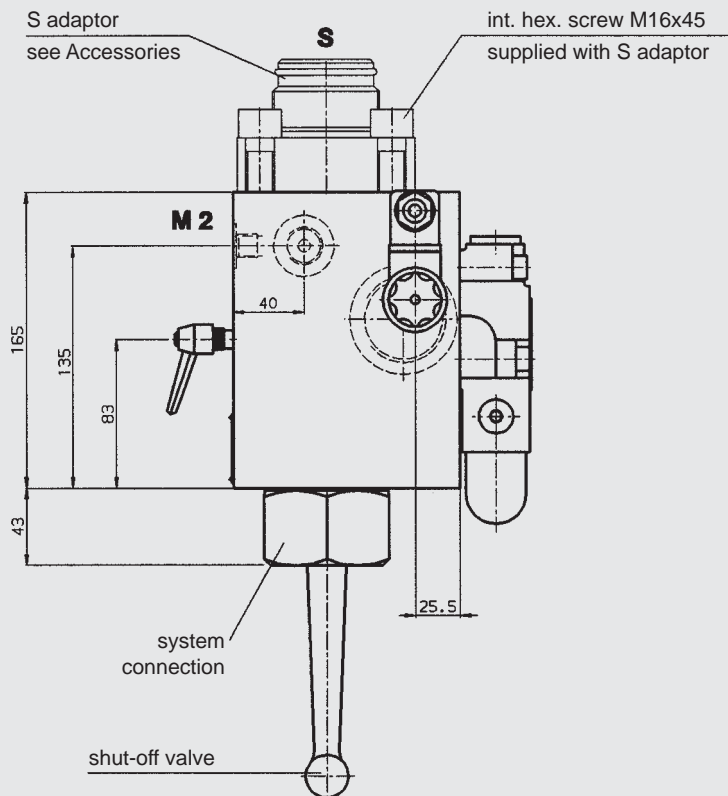
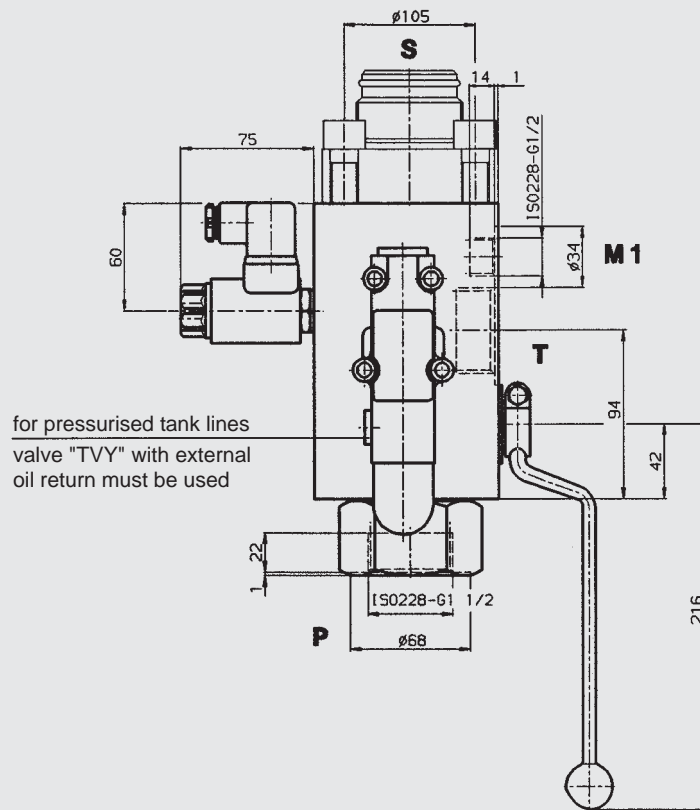

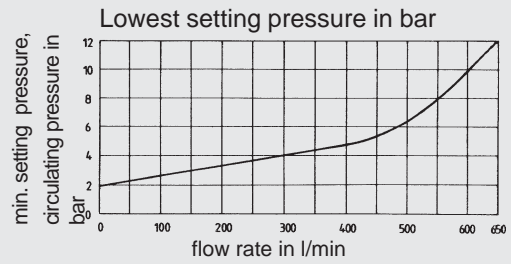
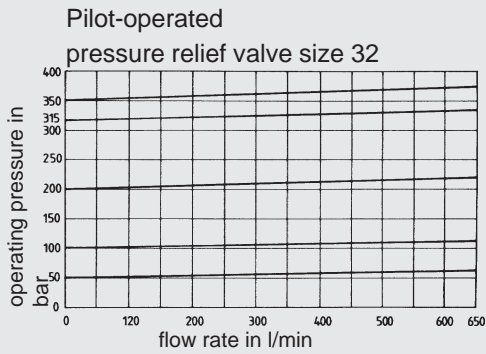
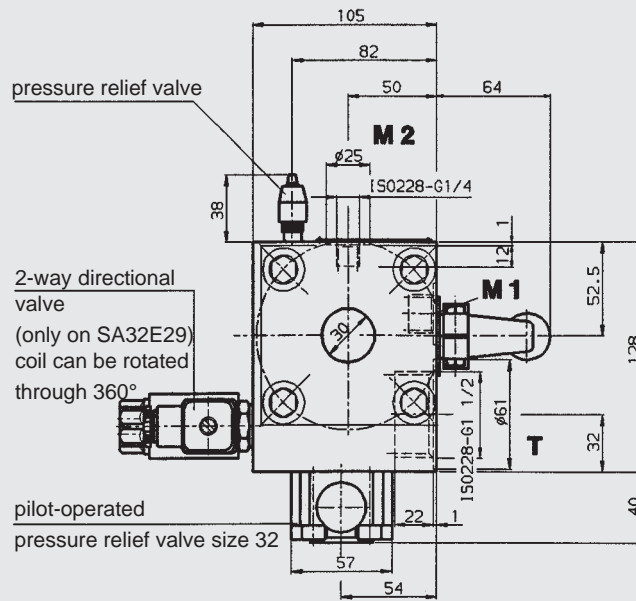

SA 3 2 E 2 9 T V Y

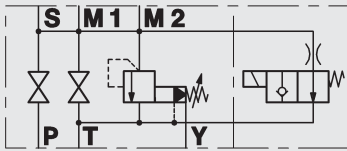

SA 3 2 E 2 9 T V

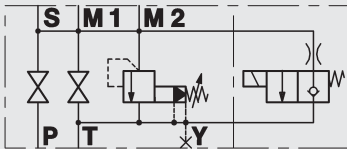

SA 3 2 M 2 9 T V Y

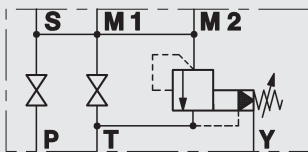

SA 3 2 M 2 9 T V

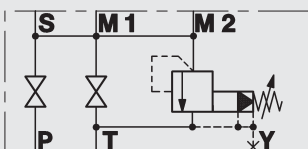

The safety and shut-off block SA32M(E)29 is equipped with a pilot-operated pressure relief valve (size 32) for high flow rates (up to 600 l/min).

The E version of the safety and shut-off block has a solenoid-operated 2-way directional valve for automatic pressure release of the accumulator and the hydraulic system in an emergency or during shut-down.

For unpressurised tank lines, valve type "TV" can be used (with internal oil return to tank).

For pressurised tank lines, valve type "TVY" is recommended (with external oil return to tank).

Two different models of the 2-way directional valve are available:

- 2SV5E2Y (open when de-energised)
- 2SV5E2Z (closed when de-energised)

Type	Weight
SA 32 M 29...	22.5 kg
SA 32 E 29...	23.5 kg

7.3. SAFETY AND SHUT-OFF BLOCK WITH ADDITIONAL EQUIPMENT

Safety and shut-off blocks are available with a device to enable the shut-off valve to be locked in either the open or closed position, by fitting a padlock.

It is also possible to fit inductive proximity switches or roller-actuated limit switches to control the open and closed position of the shut-off valve.

7.3.1 Additional device LPI

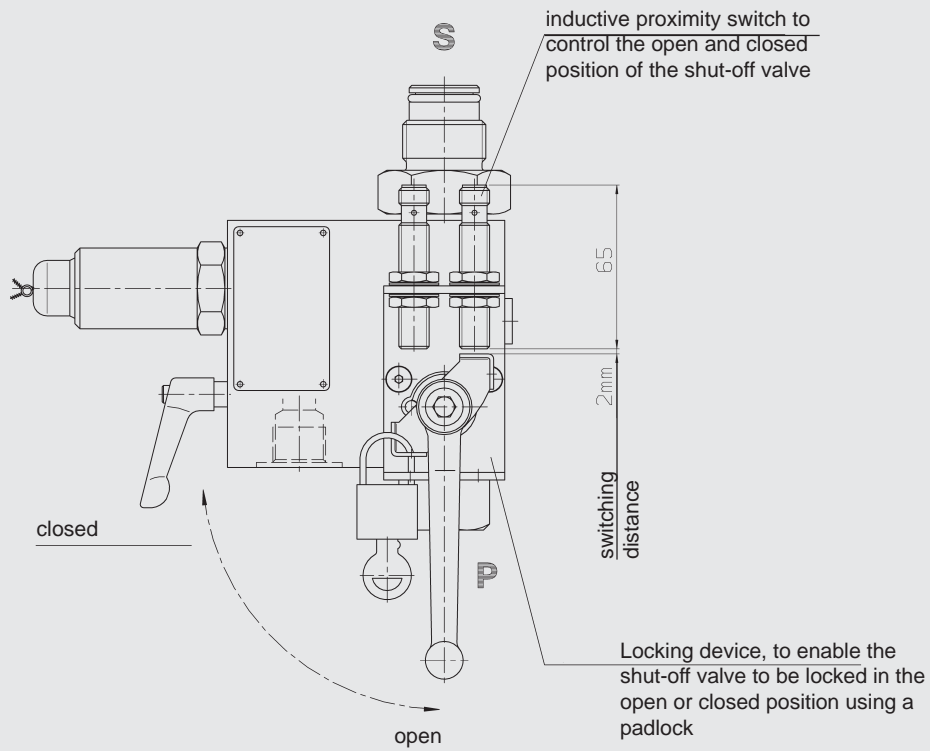

7.3.2 Additional device LPM

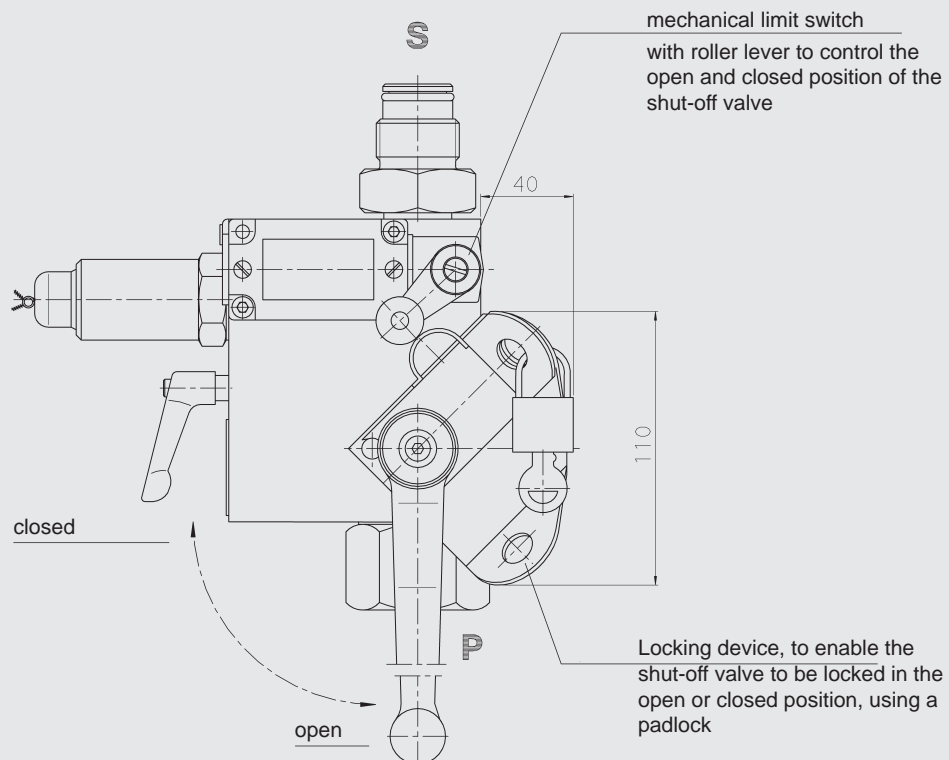

7.4. SAFETY AND SHUT-OFF BLOCK FOR HIGH FLOW RATE

The basic design of the shut-off block is the same as the standard model.

Technical specifications:

Type: SA50M60T...

Size: DN 50

Max. working pressure: 315 bar

Direct-operated pressure relief valve size 30

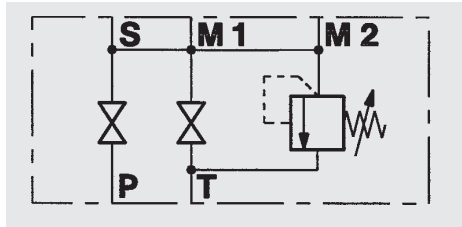

7.5. SAFETY AND SHUT-OFF BLOCK FOR FRONT PANEL MOUNTING

The safety and shut-off block consists of a valve block, a built-in pressure relief valve, a main shut-off valve and a manually operated pressure release valve.

This block is mounted on a front panel with 3 M8 screws. Ports "P" and "T" are situated on the mounting side.

Advantages:

The compact design means that the block occupies a minimum of space and ensures minimum maintenance.

Technical specifications:

Type: SA 6M10T...

Size: DN 10

Max. working pressure: 350 bar

Direct-operated pressure relief valve size 6

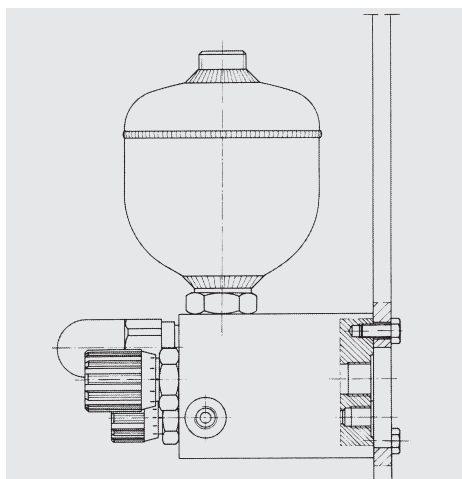
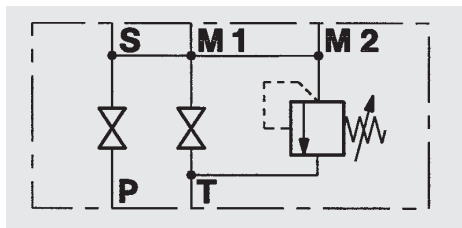

7.6. SAFETY AND SHUT-OFF BLOCK WITH 2-WAY CARTRIDGE VALVE (LOGIC ELEMENT OR LOGISTOR)

This safety and shut-off block consists of a valve block, a built-in pressure relief valve and a solenoid-operated 2-way cartridge valve which replaces the main shut-off valve.

Advantages:

In addition to its compact construction, this model is capable of rapid switching to control the oil flow.

7.6.1 Function when using 4/2 directional valve

When the 4/2 directional valve is in the switching position shown (open when de-energised), the spring chamber of the logic element is pressurised via the accumulator pressure; the path from P to S is blocked and the hydraulic accumulator is automatically shut-off from the system. By connecting the accumulator via the slip-in orifice in the pilot valve to the tank, it will slowly discharge.

When the 4/2 directional valve is in the crossed-over switching position (energised), the spring chamber of the logic element is discharged, the path from P to S is opened and the accumulator is charged.

Technical specifications:

Type	Size	max. operating pressure	Pressure relief valve
SA20A50T...	DN 20	400 bar	size 20
SA32A50T...	DN 30	315 bar	size 30
SA40A50T...	DN 40	315 bar	size 30

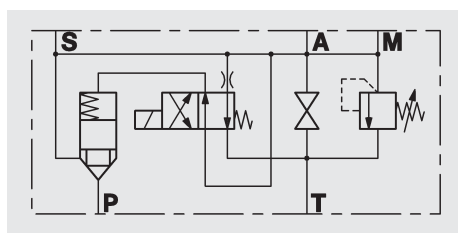

7.6.2 Function when using 3/2 directional seat valve

When the 3/2 directional seat valve is in the switching position shown (open when de-energised), the spring chamber of the logic element is pressurised via the system pressure; the path from P to S is blocked and the accumulator is shut-off from the system. When the 3/2 directional seat valve is in the discharge position (energised) the spring chamber of the logic element is discharged, the path from P to S is open and the accumulator is charged.

If the pump breaks down or if it is switched off, the 3/2 directional seat valve reverts to the "open when de-energised" position; the accumulator pressure shuts off the logic element via the shuttle change-over valve and shuts off the accumulator from the system.

Technical specifications:

Type	Size	max. operating pressure	Pressure relief valve
SA20A51T...	DN 20	400 bar	size 20
SA32A51T...	DN 30	315 bar	size 30
SA40A51T...	DN 40	315 bar	size 30

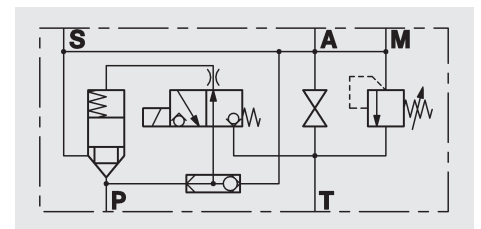

8. NOTE

The information in this brochure relates to the operating conditions and applications described. For applications or operating conditions not described, please contact the relevant technical department. Subject to technical modifications.