

KH 2/2-Wege Kugelhahn Stahl

EO 24° Anschluss / EO 24° Anschluss

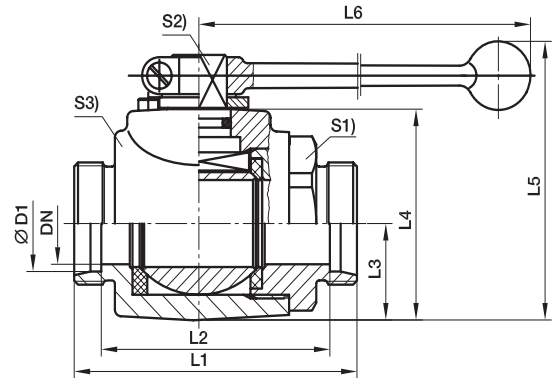

DN 4-25

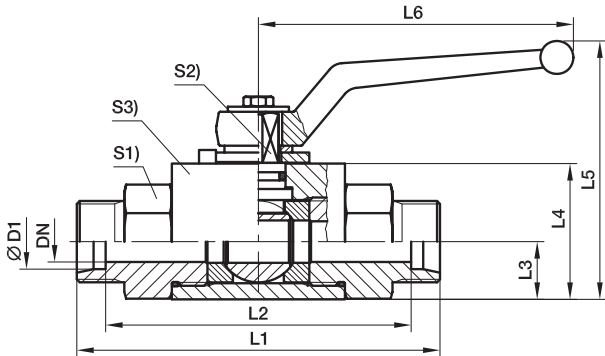
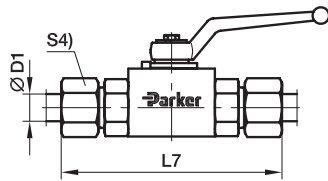

DN 32-40

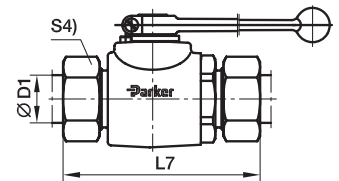

Bau-Reihe	D1	DN	L1	L2	L3	L4	L5	L6	L7	S1	S2	S3	S4	Gewicht g/1 St.	Bestellzeichen*	PN (bar) ¹⁾	
L ³⁾	06	4	67	53	10,0	25	55,0	76	82	19	7	20	14	195	KH06LX	500	
	08	6	67	53	10,0	25	55,0	76	82	19	7	20	17	190	KH08LX	500	
	10	8	75	61	14,5	35	68,0	100	90	24	8	30	19	420	KH10LX	500	
	12	10	75	61	14,5	35	68,0	100	90	24	8	30	22	410	KH12LX	500	
	15	12	83	69	17,0	40	92,0	112	99	30	10	35	27	631	KH15LX	500	
	18	16	82	67	20,0	45	105,0	166	99	36	11	45	32	850	KH18LX	400	
	22	20	99	84	24,0	55	113,0	187	116	41	14	45	36	1210	KH22LX	400	
	28	25	108	93	26,0	60	118,0	187	126	50	14	55	41	1750	KH28LX	400	
	35	25	116	95	26,0	60	118,0	187	138	50	14	55	50	1820	KH35LXDN25	400	
	35	32	121	100	36,5	80	180,5	320	143	60	17	73	50	3158	KH35LX	315	
	42	25	121	99	26,0	60	118,0	187	144	55	14	55	60	1940	KH42LXDN25	400	
	42	40	118	96	42,5	90	190,5	320	141	70	17	85	60	3788	KH42LX	315	
	S ⁴⁾	08	4	73	59	10,0	25	55,0	76	88	19	7	20	19	214	KH08SX	500
		10	6	73	58	10,0	25	55,0	76	90	19	7	20	22	220	KH10SX	500
12		8	77	62	14,5	35	68,0	100	94	24	8	30	24	430	KH12SX	500	
14		10	81	65	14,5	35	68,0	100	100	24	8	30	27	440	KH14SX	500	
16		12	87	70	17,0	40	92,0	112	106	30	10	35	30	649	KH16SX	500	
20		16	90	69	20,0	45	105,0	166	112	36	11	45	36	900	KH20SX	400	
25		20	107	83	24,0	55	113,0	187	131	41	14	45	46	1290	KH25SX	400	
30		25	120	93	26,0	60	118,0	187	146	50	14	55	50	1880	KH30SX	400	
38		25	134	102	26,0	60	118,0	187	163	55	14	55	60	1950	KH38SXDN25	400	
38		32	127	95	36,5	80	180,5	320	156	60	17	73	60	3266	KH38SX	315	

¹⁾ Druckwert genannt = Artikel lieferbar

³⁾ L = Leichte Baureihe; ⁴⁾ S = Schwere Baureihe

$$\frac{PN \text{ (bar)}}{10} = PN \text{ (MPa)}$$

Lieferung ohne Mutter und Schneidring.
Hinweise zum Bestellen von Komplettverschraubungen
bzw. alternativen Dichtungsmaterialien siehe Seite I7.

Bestellzeichen-Ergänzungen			
Material	Kennbuchstaben Oberfläche und Material	Beispiel	Standard- Dichtungswerkstoff (keine zusätzl. Kenn- buchstaben erforderlich)
Stahl, verzinkt, Cr(VI)-frei	CF	KH06LCFX	POM / NBR
Stahl	DIN 50938-FE//A/T4	KH06LX	POM / NBR