



aerospace  
climate control  
electromechanical  
filtration  
fluid & gas handling  
hydraulics  
**pneumatics**  
process control  
sealing & shielding



# P3Y Series Air preparation system

3/4" & 1" Body ported

Catalogue no. PDE2631TCUK - February 2010



ENGINEERING YOUR SUCCESS.

# Table of Contents

---

Recommended wall mountings .....	4
Popular combinations .....	5
Filters .....	6 - 7
Dust Filters .....	8 - 9
Coalescing filters .....	10 - 11
Adsorber filters .....	12 - 13
Regulators .....	14 - 15
Filter regulators .....	16 - 17
Lubricators .....	18 - 19
Proportional pressure regulator .....	20 - 21
Combined soft start dump valve .....	22 - 23
Remote operated dump valve .....	22 - 23
Soft Start valve .....	24 - 25
Pilot operated regulator .....	26 - 27
Modular ball valve .....	28
Modular manifold .....	29
Optional port block kits .....	29
Accessories .....	30

 **WARNING**

FAILURE OR IMPROPER SELECTION OR IMPROPER USE OF THE PRODUCTS AND/OR SYSTEMS DESCRIBED HEREIN OR RELATED ITEMS CAN CAUSE DEATH, PERSONAL INJURY AND PROPERTY DAMAGE.

This document and other information from Parker Hannifin Corporation, its subsidiaries and authorized distributors provide product and/or system options for further investigation by users having technical expertise. It is important that you analyze all aspects of your application and review the information concerning the product or system in the current product catalog. Due to the variety of operating conditions and applications for these products or systems, the user, through its own analysis and testing, is solely responsible for making the final selection of the products and systems and assuring that all performance, safety and warning requirements of the application are met. The products described herein, including without limitation, product features, specifications, designs, availability and pricing, are subject to change by Parker Hannifin Corporation and its subsidiaries at any time without notice.

**SALE CONDITIONS**

The items described in this document are available for sale by Parker Hannifin Corporation, its subsidiaries or its authorized distributors. Any sale contract entered into by Parker will be governed by the provisions stated in Parker's standard terms and conditions of sale (copy available upon request).

**The System**

The P3Y system allows units to be connected together, without the use of pipe connectors, saving space; providing constant mounting centres; whilst maintaining a modern aesthetically pleasing appearance.

The P3Y Filters are specially designed to efficiently filter out rust, dirt, moisture and other impurities from compressed air lines. Operation is fully automatic with a minimum of pressure drop. Coalescing filters and adsorber filters for high purity air are also included in the P3Y series.

The P3Y Regulators are designed to provide quick response and accurate pressure regulation for the most demanding hi-flow industrial applications. The rolling diaphragm was designed for long trouble-free operation and will not rupture or tear under high cycle or other demanding applications.

The P3Y mist lubricators are designed to provide lubrication for many general purpose applications in a pneumatic system.

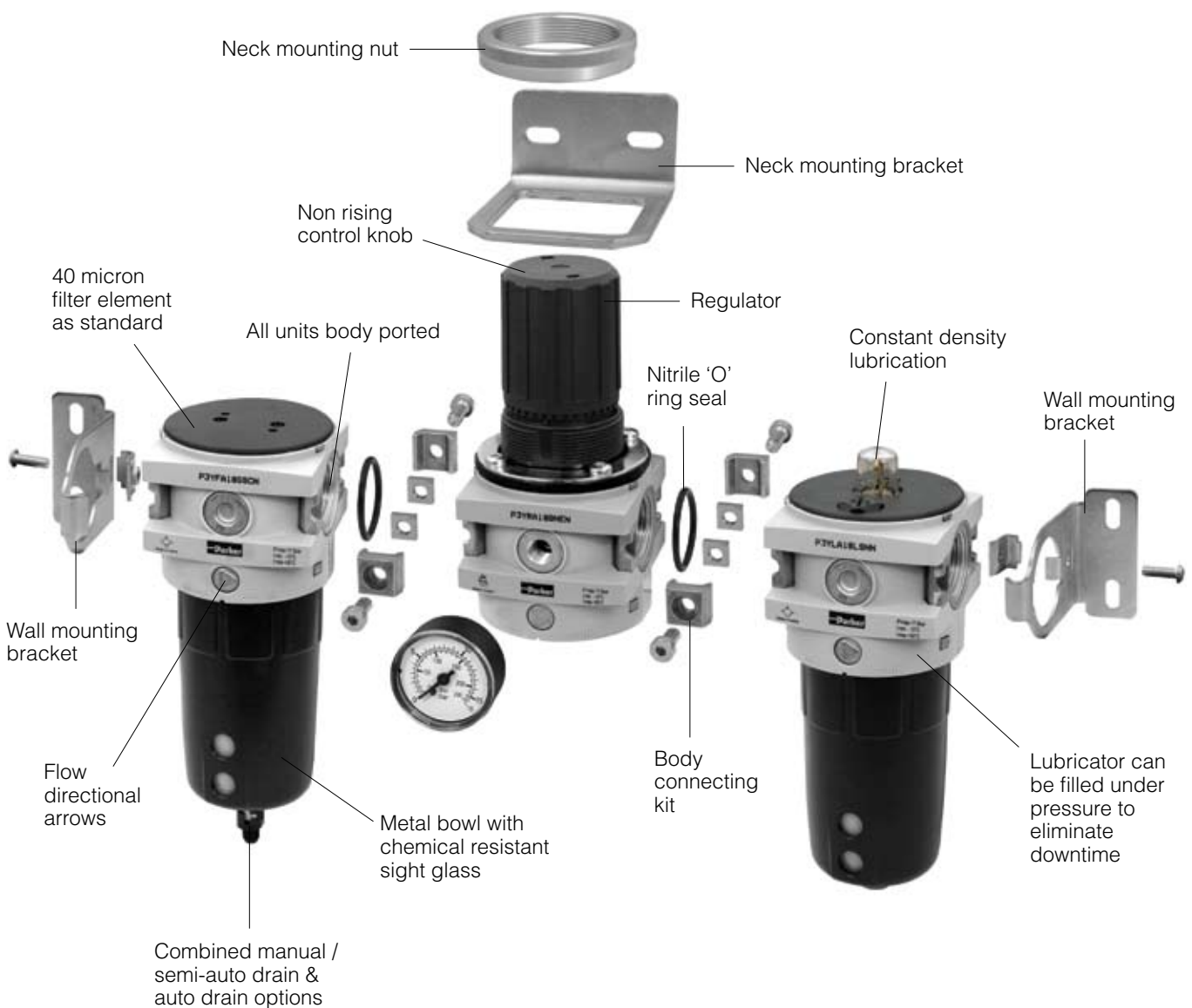

**Recommended Wall Mounting Configurations**

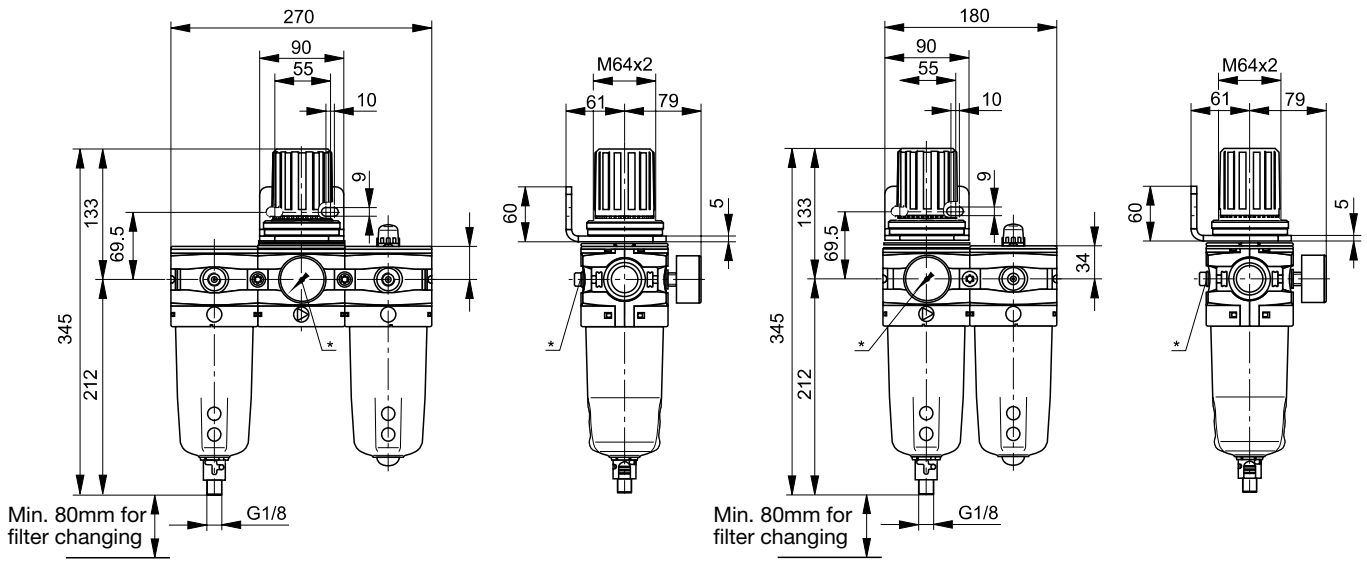

\* Gauge port 1/4"

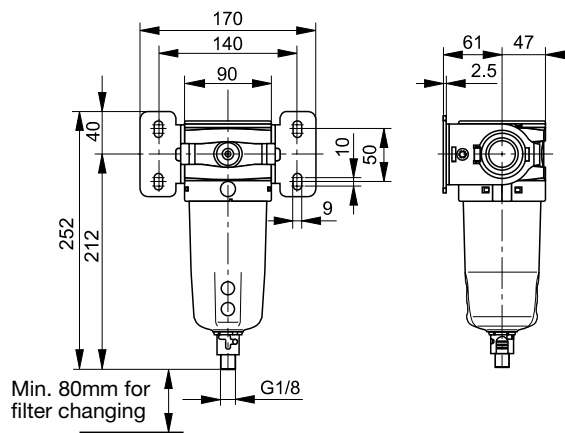

**Popular Combinations**

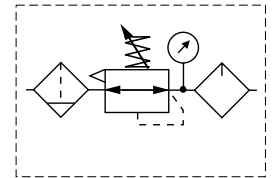

**Filter + Regulator + Lubricator Combinations**  
**40 micron element, 12 bar Regulator + Gauge and Wall Mounting Bracket**

Port size	Combined Manual/Semi-Auto Drain	Flow dm <sup>3</sup> /s	Weight (kg)	Auto Drain	Flow dm <sup>3</sup> /s	Weight (kg)
G <sup>3</sup> / <sub>4</sub>	<b>P3YCB16SGCNFLNF</b>	91	3.3	<b>P3YCB16SGANFLNF</b>	91	3.3
G1	<b>P3YCB18SGCNFLNF</b>	174	3.3	<b>P3YCB18SGANFLNF</b>	174	3.3

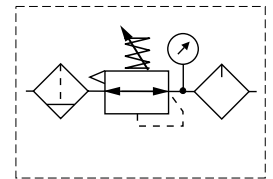

**Filter/Regulator + Lubricator Combinations**  
**40 micron element, 12 bar Regulator + Gauge and Wall Mounting Bracket**

Port size	Combined Manual/Semi-Auto Drain	Flow dm <sup>3</sup> /s	Weight (kg)	Auto Drain	Flow dm <sup>3</sup> /s	Weight (kg)
G <sup>3</sup> / <sub>4</sub>	<b>P3YCA16SGCNFLNF</b>	101	2.8	<b>P3YCA16SGANFLNF</b>	101	2.8
G1	<b>P3YCA18SGCNFLNF</b>	168	2.8	<b>P3YCA18SGANFLNF</b>	168	2.8

\* Flow measured with 10 bar inlet pressure, 6.3 bar set pressure, 1 bar pressure drop.

**Options:**

<b>P 3 Y</b>	<b>C</b>				<b>S G</b>		<b>N</b>		<b>L N F</b>
Filter/Regulator + Lub	<b>A</b>	BSPP (G)	<b>1</b>	3/4	Combined Manual/Semi Auto Drain	<b>C</b>	0 - 12 bar with gauge	<b>F</b>	
Filter + Regulator + Lub	<b>B</b>	NPT	<b>9</b>	1	Auto Drain	<b>A</b>	0 - 16 bar with gauge	<b>J</b>	

**Filter**



**Symbols**

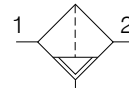

Manual / Semi auto drain

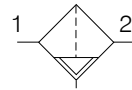

Auto drain

- Integral 3/4 or 1" ports (BSPP & NPT)
- High efficiency particulate element as standard
- Excellent water removal efficiency
- Robust but lightweight aluminium construction

**Options:**

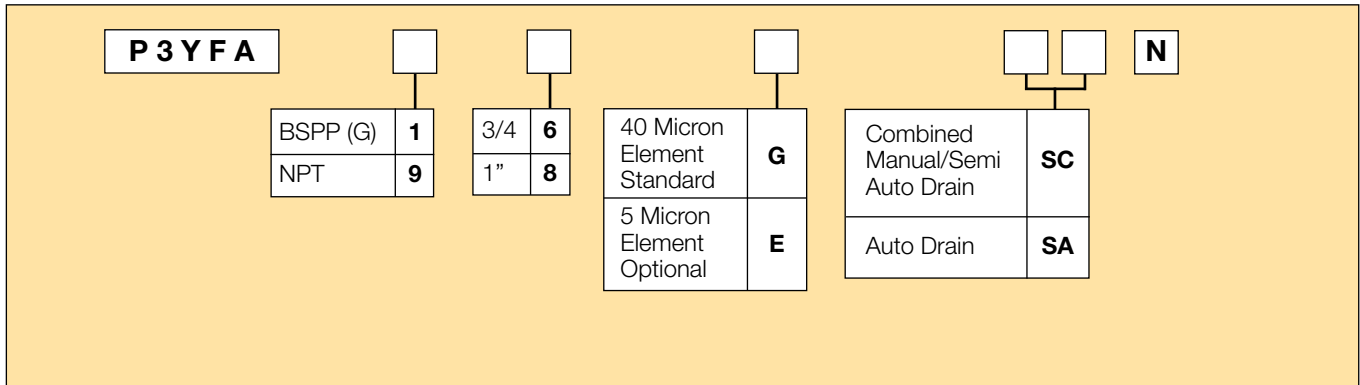

Port size	Description	Order Code	Flow dm <sup>3</sup> /s *	Max bar	Min temp °C	Max temp °C	Bowl capacity cm <sup>3</sup>	Height mm	Width mm	Depth mm	Weight kg
3/4	Combined manual/ semi auto drain	<b>P3YFA16GSCN</b>	116	17.5	-10	60	130	244	90	94	0.9
3/4	Auto drain	<b>P3YFA16GSAN</b>	116	17.5	-10	60	130	244	90	94	0.9
1"	Combined manual/ semi auto drain	<b>P3YFA18GSCN</b>	119	17.5	-10	60	130	244	90	94	0.9
1"	Auto drain	<b>P3YFA18GSAN</b>	119	17.5	-10	60	130	244	90	94	0.9

\* flow with 6,3 bar inlet pressure and 0,5 pressure drop.

**Technical Information**

Fluid:	Compressed air
Maximum inlet pressure*:	17.5 bar
Temperature range*:	-10°C to +60°C
Particle removal:	5 & 40 micron
Air quality:	Within ISO 8573-1 : 1991 Class 3 and 5 (particulates) Within ISO 8573-1 : 2001 Class 6 and 7 (particulates)
Typical flow with 40µm element 6,3 bar inlet pressure and 0.5 bar pressure drop:	119 dm <sup>3</sup> /s
Manual/Semi-auto drain:	Closed at 0.8 bar G1/8 thread
Auto drain: bowl pressure to close drain Operating range manual override facility (depress pin)	0.8 bar 0.8 to 17.5 bar Ø 10mm brass connection
Bowl sump capacity:	130 cm <sup>3</sup>

\* Air supply must be dry enough to avoid ice formation at temperatures below +2°C

**Material Specification**

Body:	Aluminium
Sight glass:	Polypropylene
Body cover:	ABS
Element:	Sintered P.E.
Seals:	Nitrile NBR
Drains:	Manual / Semi-auto: Acetal Automatic: PA / Brass connection

**Dimensions (mm)**

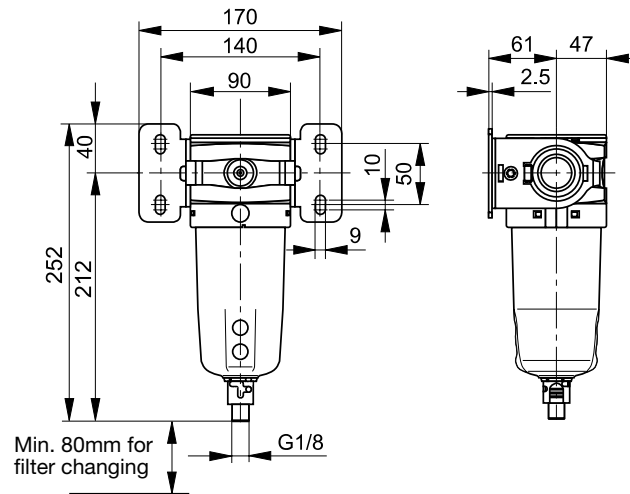

**Service kits**

Description	Order code
5 micron element kit	<b>P3YKA00ESE</b>
40 micron element kit	<b>P3YKA00ESG</b>
Bowl kit with combined manual/semi auto drain	<b>P3YKA00BSC</b>
Bowl kit with auto drain	<b>P3YKA00BSA</b>

**Flow characteristics**

**(3/4) 40 Micron Filter**

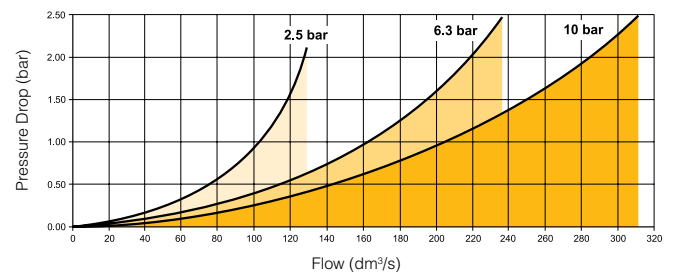

**(1") 40 Micron Filter**

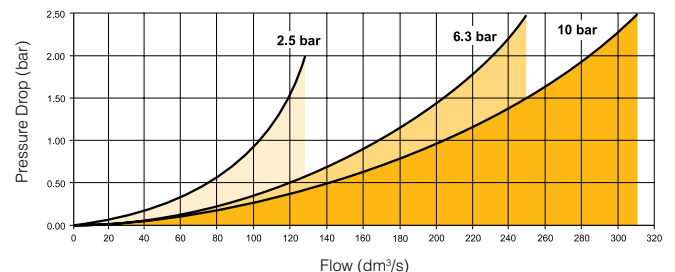

**Dust Filter**



- Extended dust filter element provides greater filtration surface area.
- Integral 3/4 or 1" ports (BSPP & NPT)
- Removes dust particles
- Dust free air for critical applications, such as air gauging, pneumatic instrumentation and control

**Note:** To optimise the life of the dust 1µm element, it is advisable to install a P3YFA pre-filter with a 5 or 40 micron element upstream of the coalescing filter.

**Options:**

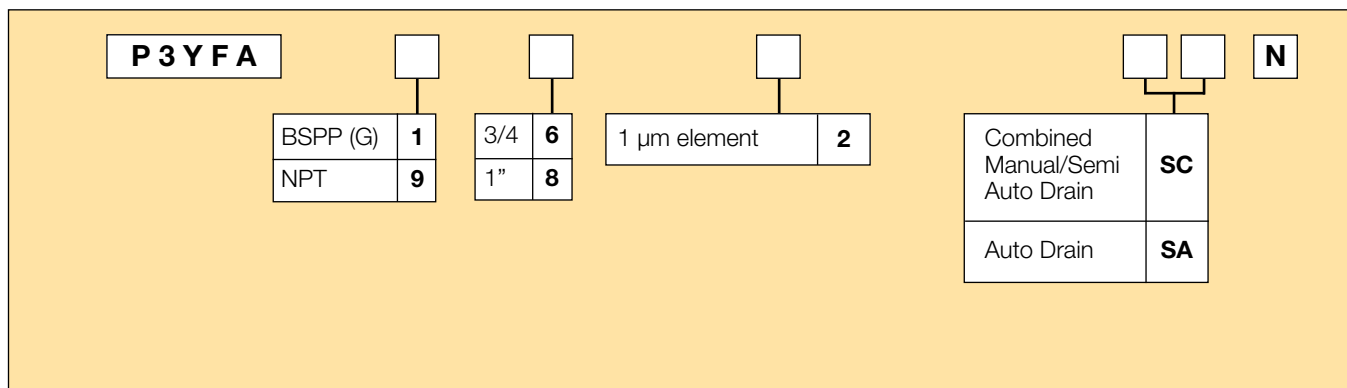

Port size	Description	Order Code	Flow dm <sup>3</sup> /s *	Max bar	Min temp °C	Max temp °C	Bowl capacity cm <sup>3</sup>	Height mm	Width mm	Depth mm	Weight kg
3/4	Dust Filter 1µm, Combined manual/semi auto drain	<b>P3YFA162SCN</b>	137	17.5	-10	60	130	360	90	94	1.6
3/4	Dust Filter 1µm, auto drain	<b>P3YFA162SAN</b>	137	17.5	-10	60	130	360	90	94	1.6
1"	Dust Filter 1µm, Combined manual/semi auto drain	<b>P3YFA182SCN</b>	145	17.5	-10	60	130	360	90	94	1.6
1"	Dust Filter 1µm, auto drain	<b>P3YFA182SAN</b>	145	17.5	-10	60	130	360	90	94	1.6

\* flow with 6,3 bar inlet pressure and 0,5 pressure drop



**Technical Information**

Fluid:	Compressed air
Maximum inlet pressure*:	17.5 bar
Temperature range*:	-10°C to +60°C
Typical flow element @ 6,3 bar inlet pressure and 5 bar pressure drop:	145 dm <sup>3</sup> /s
Manual/Semi-auto drain:	Bowl pressure to close drain 0.8 bar G1/8" thread
Auto drain: bowl pressure to close drain Operating range manual override facility (depress pin)	0.8 bar 0.8 to 17.5 bar Ø 10mm brass connection
Bowl sump capacity:	130 cm <sup>3</sup>

\* Air supply must be dry enough to avoid ice formation at temperatures below +2°C

**Material Specification**

Body:	Aluminium
Sight glass:	Polypropylene
Filter cover:	ABS
Seals:	Nitrile NBR
Drains:	Manual / Semi-auto: Acetal Automatic: PA / Brass connection
Coalescing element:	Borosilicate & Nano fibres
Top & bottom end cap:	Aluminium
Support cylinders:	Grade 430 stainless steel
Support media:	Polypropylene
Ensapulate:	Epoxy resin / Hardener

**Dimensions (mm)**

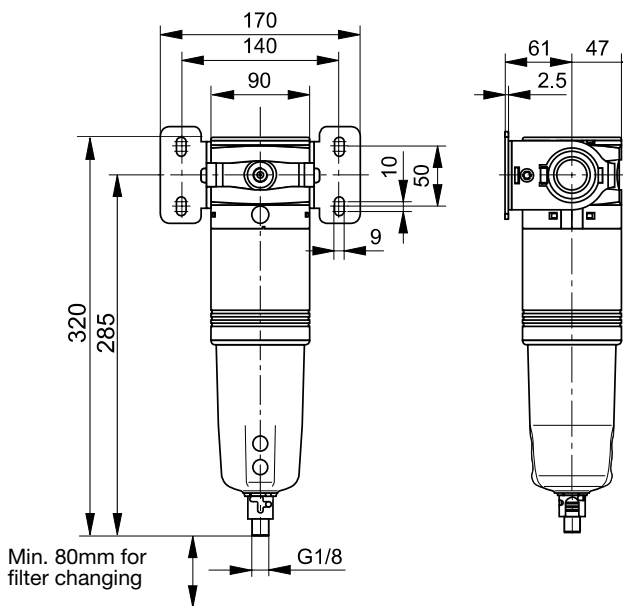

**Flow characteristics**

**(1") 1µm Dust Filter Saturated**

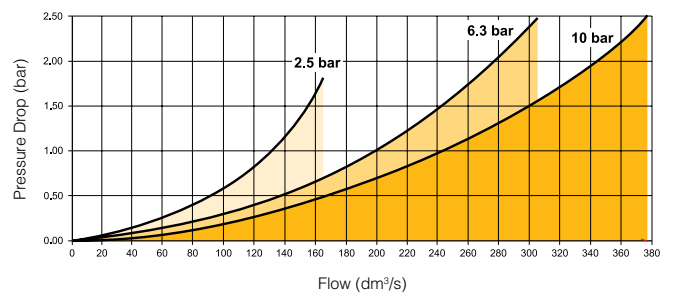

**Service kits**

Description	Order code
1 micron coalescing element kit	<b>P3YKA00ES9</b>
Bowl kit with combined manual/semi auto drain	<b>P3YKA00BSC</b>
Bowl kit with auto drain	<b>P3YKA00BSA</b>



**Technical Information**

Fluid:	Compressed air
Maximum inlet pressure*:	17.5 bar
Temperature range*:	-10°C to +60°C
Media specifications:	
Coalescing efficiency	(0.3 to 0.6 micron particles): 99.97%
Max. oil carryover (PPM w/w):	0.008 mg/m <sup>3</sup>
Typical flow element @ 6,3 bar inlet pressure and 0.2 bar pressure drop:	Dry element 0.01µm @ 59dm <sup>3</sup> /s
Manual/Semi-auto drain:	Bowl pressure to close drain 0.8 bar G1/8" thread
Auto drain:	
bowl pressure to close drain	0.8 bar
Operating range manual override facility (depress pin)	0.8 to 17.5 bar Ø 10mm brass connection
Bowl sump capacity:	130 cm <sup>3</sup>

\* Air supply must be dry enough to avoid ice formation at temperatures below +2°C

**Material Specification**

Body:	Aluminium
Sight glass:	Polypropylene
Filter cover:	ABS
Coalescing element:	Borosilicate & Nano fibres
Top & bottom end cap:	Aluminium
Support cylinders:	Grade 430 stainless steel
Support media:	Polypropylene
Anti re-entrainment barrier:	Polyester
Ensapulate:	Epoxy resin / Hardener
Seals:	Nitrile NBR
Drains:	Manual / Semi-auto: Acetal Automatic: PA / Brass connection
Differential pressure indicator materials:	
Body:	Acetal
Internal parts:	Acetal
Spring:	Stainless steel
Seals:	Nitrile NBR
Support plate	ABS
Screws	Steel / zinc plated

**Dimensions (mm)**

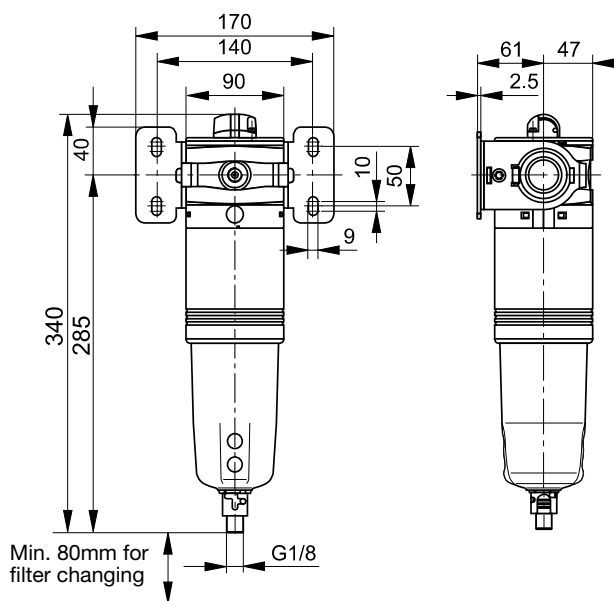

**Service kits**

Description	Order code
0.01 micron coalescing element kit	<b>P3YKA00ESC</b>
Bowl kit with combined manual/semi auto drain	<b>P3YKA00BSC</b>
Bowl kit with auto drain	<b>P3YKA00BSA</b>
Differential pressure indicator kit	<b>P3YKA00RQ</b>

**Flow characteristics**

**(3/4) 0.01µm Coalescing Filter Saturated**

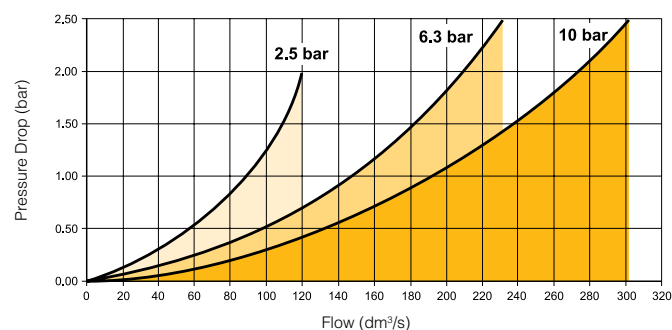

**(1") 0.01µm Coalescing Filter Saturated**

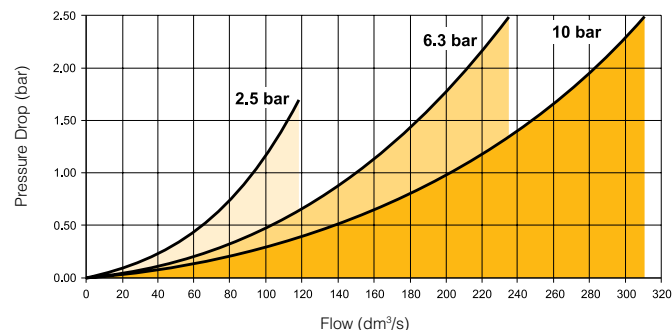

**Adsorber Filter**



- Integral 3/4 or 1" ports (BSPP & NPT)
- Adsorber activated carbon element removes oil vapours and most hydrocarbons

**Note:** To optimise the life of the adsorber element, it is advisable to install a P3Y coalescing 0.01 µm filter upstream of the adsorber filter.

**Options:**

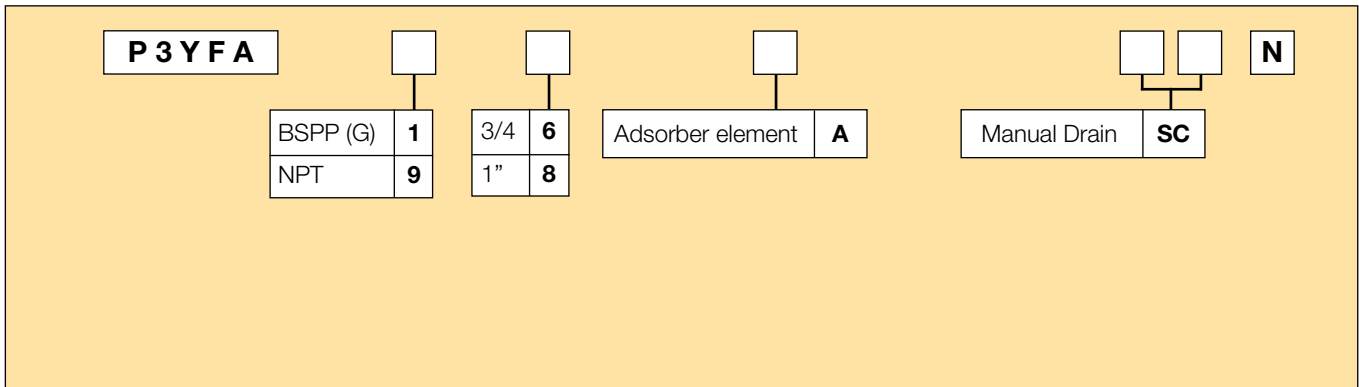

Port size	Description	Order Code	Flow dm <sup>3</sup> /s *	Max bar	Min temp °C	Max temp °C	Bowl capacity cm <sup>3</sup>	Height mm	Width mm	Depth mm	Weight kg
3/4	Adsorber Filter, Manual drain	<b>P3YFA16ASCN</b>	47	17.5	-10	60	130	340	90	94	1.5
1"	Adsorber Filter, Manual drain	<b>P3YFA18ASCN</b>	50	17.5	-10	60	130	340	90	94	1.5

\* flow with 6,3 bar inlet pressure and 0,2 pressure drop

**Technical Information**

Fluid:	Compressed air	
Maximum inlet pressure*:	17.5 bar	
Temperature range*:	-10°C to +60°C	
Media specifications:		
Max. oil carryover (PPM w/w):	0.008 mg/m <sup>3</sup>	
Typical flow at 6,3 bar inlet pressure and 0.2 bar pressure drop:	1" Adsorber	50 dm <sup>3</sup> /s
Manual drain / Semi-auto drain:	G1/8" thread	
Bowl sump capacity:	130 cm <sup>3</sup>	

\* Air supply must be dry enough to avoid ice formation at temperatures below +2°C

**Material Specification**

Body:	Aluminium
Sight glass:	Polypropylene
Filter cover:	ABS
Adsorber element:	Activated carbon
Top & bottom endcap:	Glass filled nylon
Seals:	Nitrile NBR
Bayonet support:	Nylon
Drain: Manual / Semi-auto:	Acetal

**Dimensions (mm)**

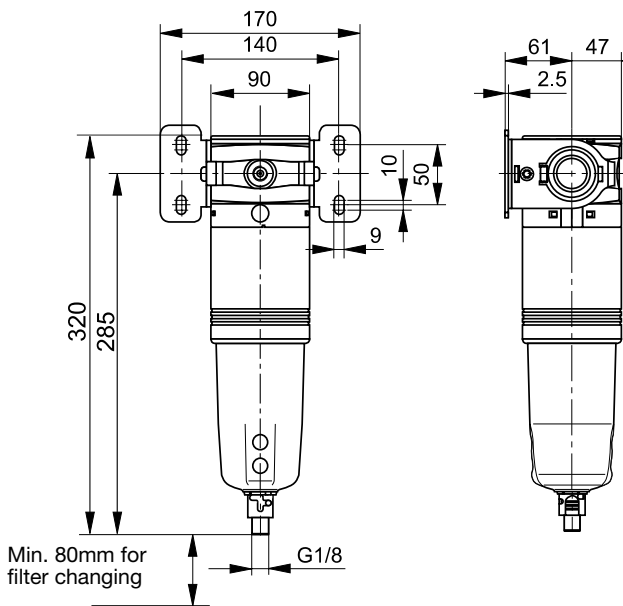

**Flow characteristics**

**(3/4) Adsorber Filter**

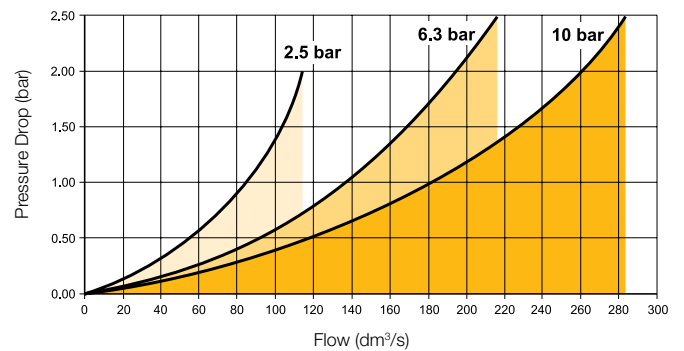

**(1") Adsorber Filter**

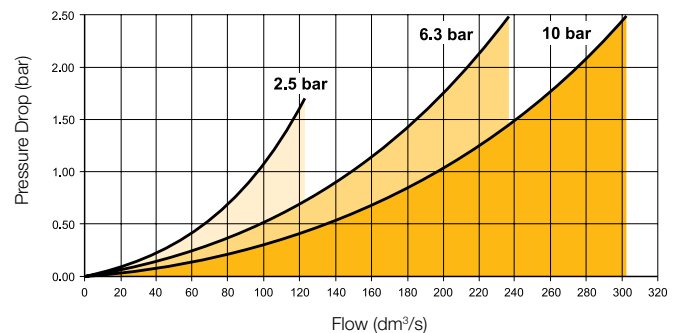

**Service kits**

Description	Order code
Adsorber element kit	<b>P3YKA00ESA</b>
Bowl kit with manual / semi-auto drain	<b>P3YKA00BSC</b>

**Regulator**



**Symbols**

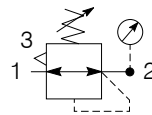

Self relieving regulator with gauge

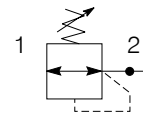

Non relieving regulator

- Integral 3/4 or 1" ports (BSPP & NPT)
- Robust but lightweight aluminium construction
- Secondary pressure ranges 12 & 16 bar
- Rolling diaphragm for extended life
- Secondary aspiration plus rolling diaphragm provides quick response and accurate pressure regulation.
- Optional tamperproof regulator padlock
- Relieving & Non-relieving types

**Options:**

<b>P 3 Y R A</b>	□	□	□	□	□	□	<b>N</b>		
BSPP (G)	<b>1</b>	3/4	<b>6</b>	Relieving	<b>B</b>	Standard	<b>N</b>	0 - 12 bar No Gauge	<b>E</b>
NPT	<b>9</b>	1"	<b>8</b>	Non-relieving	<b>N</b>	Lockable type	<b>A</b>	0 - 16 bar No Gauge	<b>H</b>
								0 - 12 bar Gauge	<b>F</b>
								0 - 16 bar Gauge	<b>J</b>

Port size	Description	Order Code	Flow dm <sup>3</sup> /s *	Max bar	Min temp °C	Max temp °C	Height mm	Width mm	Depth mm	Weight kg
3/4	12 bar relieving	<b>P3YRA16BNEN</b>	155	17.5	-10	60	182	90	94	1.08
3/4	12 bar relieving + pressure gauge	<b>P3YRA16BNFN</b>	155	17.5	-10	60	182	90	94	1.13
1"	12 bar relieving	<b>P3YRA18BNEN</b>	321	17.5	-10	60	182	90	94	1.08
1"	12 bar relieving + pressure gauge	<b>P3YRA18BNFN</b>	321	17.5	-10	60	182	90	94	1.19
3/4	12 bar relieving, lockable	<b>P3YRA16BAEN</b>	155	17.5	-10	60	182	90	94	1.08
3/4	12 bar relieving lockable, + pressure gauge	<b>P3YRA16BAFN</b>	155	17.5	-10	60	182	90	94	1.13
1"	12 bar relieving, lockable	<b>P3YRA18BAEN</b>	321	17.5	-10	60	182	90	94	1.08
1"	12 bar relieving, lockable + pressure gauge	<b>P3YRA18BAFN</b>	321	17.5	-10	60	182	90	94	1.19

\* Flow with 10 bar inlet pressure, 6,3 bar set pressure and 1 bar pressure drop.

Lockable regulators will require key lock kit (opposite page).

**Technical Information**

Fluid:	Compressed air
Maximum inlet pressure*:	17.5 bar
Temperature range*:	-10°C to +60°C
Typical flow with 10 bar inlet pressure, 6.3 bar set pressure and 1 bar pressure drop:	1" size 321 dm <sup>3</sup> /s
Gauge port ( x 2):	1/4"

\* Air supply must be dry enough to avoid ice formation at temperatures below +2°C

**Material Specification**

Body:	Aluminium
Bonnet:	Glass filled polyamide
Regulator cover:	ABS
Control Knob:	Glass filled polyamide
Valve:	Brass / NBR
Seals:	Nitrile NBR
Screws:	Steel / zinc plated

**Dimensions (mm)**

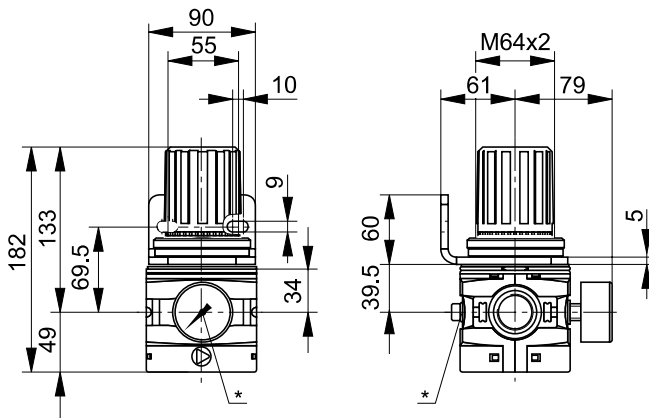

\* 1/4" gauge port

**Service kits**

Description	Order code
Angle bracket + metal lock ring	<b>P3YKA00MS</b>
Panel mounting nut	<b>P3YKA00MM</b>
Key lock	<b>P3XKA00AS</b>
Diaphragm kit (relieving type)	<b>P3YKA00RR</b>
Diaphragm kit (non-relieving type)	<b>P3YKA00RN</b>

**Key Lock Kit**

This facilitates the tamperproofing of the lockable Regulators and Filter-Regulator units on request.



**Order code**

**P3XKA00AS**

**Flow characteristics**

**Regulation characteristics: (3/4)**

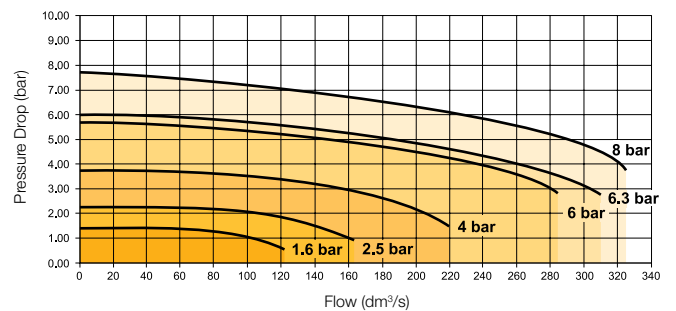

**Regulation characteristics: (1")**

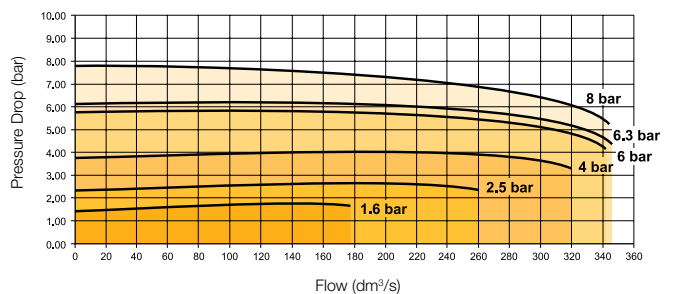

**Filter-Regulator**



**Symbols**

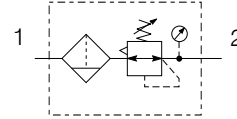

- Integral 3/4 or 1" ports (BSPP or NPT)
- High efficiency element as standard
- Excellent water removal efficiency
- Robust but lightweight aluminium construction
- Secondary pressure ranges 12 and 16 bar
- Rolling diaphragm for extended life
- Secondary aspiration plus balanced poppet provides quick response and accurate pressure regulation.

**Options:**

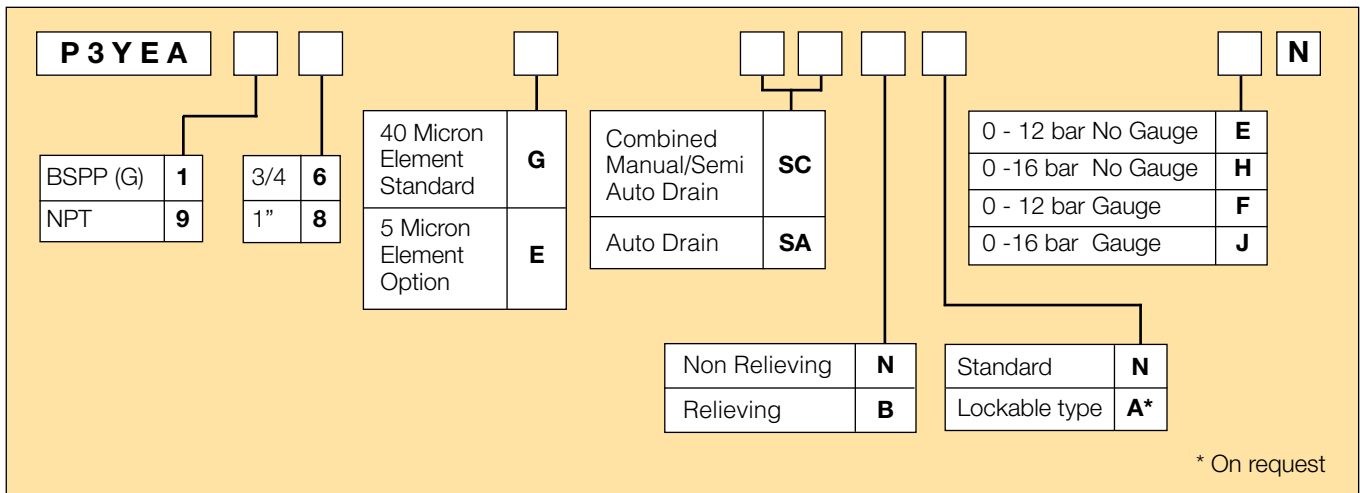

Port size	Description	Order Code	Flow dm <sup>3</sup> /s *	Max bar	Min temp °C	Max temp °C	Bowl capacity cm <sup>3</sup>	Height mm	Width mm	Depth mm	Weight kg
3/4	12 bar, relieving, Combined manual/semi auto drain	<b>P3YEA16GSCBNEN</b>	190	17.5	-10	60	130	345	90	94	1.5
3/4	12 bar relieving, auto drain	<b>P3YEA16GSABNEN</b>	190	17.5	-10	60	130	345	90	94	1.5
3/4	12 bar, relieving, gauge Combined manual/semi auto drain	<b>P3YEA16GSCBNFN</b>	190	17.5	-10	60	130	345	90	94	1.5
3/4	12 bar relieving, gauge, auto drain	<b>P3YEA16GSABNFN</b>	190	17.5	-10	60	130	345	90	94	1.5
1"	12 bar, relieving, Combined manual/semi auto drain	<b>P3YEA18GSCBNEN</b>	237	17.5	-10	60	130	345	90	94	1.5
1"	12 bar relieving, auto drain	<b>P3YEA18GSABNEN</b>	237	17.5	-10	60	130	345	90	94	1.5
1"	12 bar, relieving, gauge Combined manual/semi auto drain	<b>P3YEA18GSCBNFN</b>	237	17.5	-10	60	130	345	90	94	1.5
1"	12 bar relieving, gauge, auto drain	<b>P3YEA18GSABNFN</b>	237	17.5	-10	60	130	345	90	94	1.5

\* flow with 10 bar inlet pressure, 6,3 bar set pressure and 1 bar pressure drop.



**Technical Information**

Fluid:	Compressed air
Maximum inlet pressure*:	17.5 bar
Temperature range*:	-10°C to +60°C
Particle removal:	5 micron and 40 micron
Air quality:	Within ISO 8573-1 : 1991 Class 3 and 5 (particulates) Within ISO 8573-1 : 2001 Class 6 and 7 (particulates)
Typical flow with 10 bar inlet pressure 6,3 bar set pressure and 1 bar pressure drop 1" size 237 dm <sup>3</sup> /s	
Manual/Semi-auto drain:	0,8 bar bowl pressure to close drain G1/8" thread
Auto drain:	
bowl pressure to close drain	0.8 bar
Operating range	0.8 to 17.5 bar
manual override facility (depress pin)	Ø 10mm brass connection
Bowl sump capacity:	130 cm <sup>3</sup>
Gauge ports ( x 2 ):	1/4"

\* Air supply must be dry enough to avoid ice formation at temperatures below +2°C

**Material Specification**

Body:	Aluminium
Sight glass:	Polypropylene
Body cover:	ABS
Element:	Sintered polypropylene
Seals:	Nitrile NBR
Drains:	Manual / Semi-auto: Acetal Automatic: PA / Brass connection
Bonnet:	Glass filled polyamide
Control knob:	Glass filled polyamide
Valve:	Brass / NBR
Screws:	Steel/ zinc plated

**Dimensions (mm)**

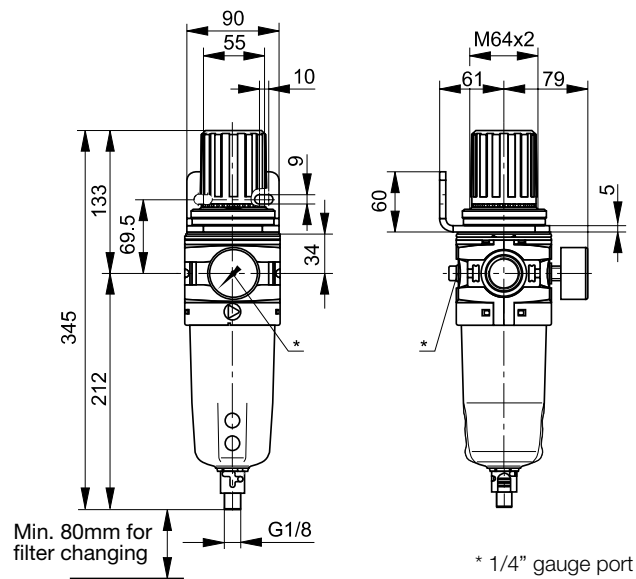

**Service kits**

Description	Order code
5 micron element kit	<b>P3YKA00ESE</b>
40 micron element kit	<b>P3YKA00ESG</b>
Bowl kit with combined manual/semi auto drain	<b>P3YKA00BSC</b>
Bowl kit with auto drain	<b>P3YKA00BSA</b>
Key Lock Kit	<b>P3XKA00AS</b>
Diaphragm kit (relieving type)	<b>P3YKA00RR</b>
Diaphragm kit (non-relieving type)	<b>P3YKA00RN</b>
Angle bracket + metal lock ring	<b>P3YKA00MS</b>
Panel mount nut	<b>P3YKA00MM</b>

**Flow characteristics**

**(3/4) 40 Micron Filter/Regulator**

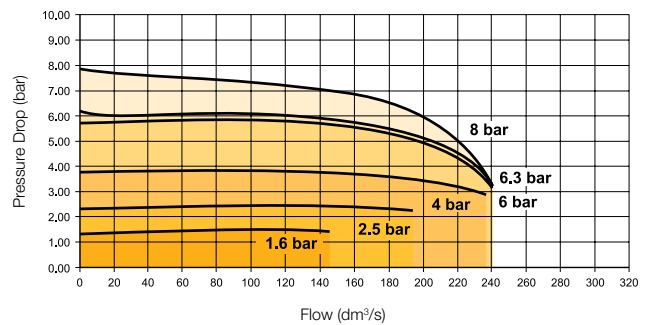

**(1") 40 Micron Filter/Regulator**

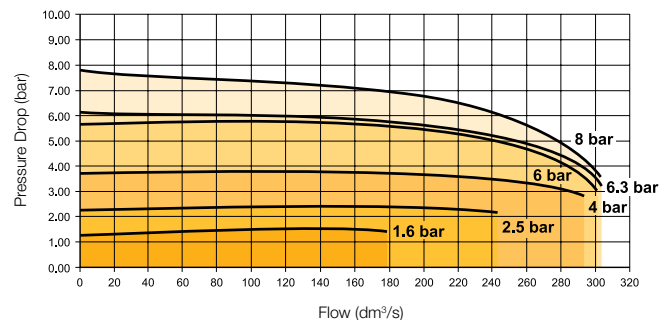

**Lubricator**



**Symbols**

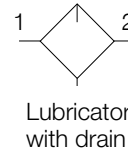

- Integral 3/4 or 1" ports (BSPP & NPT)
- Robust but lightweight aluminium construction
- Proportional oil delivery over a wide range of air flows.
- Possible to fill under system pressure eliminating down time
- Large oil reservoir

**Options:**

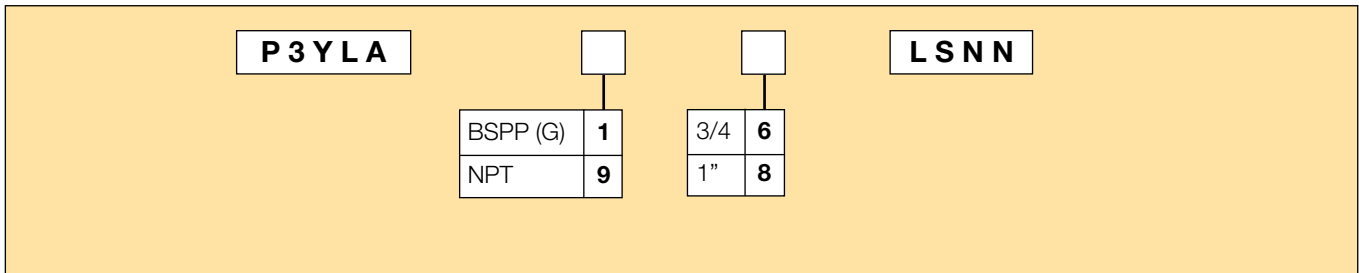

Port size	Description	Order Code	Flow dm <sup>3</sup> /s *	Max bar	Min temp °C	Max temp °C	Bowl capacity cm <sup>3</sup>	Height mm	Width mm	Depth mm	Weight kg
3/4	Oil mist, fill under pressure	<b>P3YLA16LSNN</b>	162	17.5	-10	60	500	247	90	94	0.8
1"	Oil mist, fill under pressure	<b>P3YLA18LSNN</b>	184	17.5	-10	60	500	247	90	94	0.8

\* flow with 6,3 bar inlet pressure and 0,5 pressure drop.

**Technical Information**

Fluid:	Compressed air
Maximum inlet pressure*:	17.5 bar
Temperature range*:	-10°C to +60°C

\* Air supply must be dry enough to avoid ice formation at temperatures below +2° C  
 Low flow start point (lubrication pick-up): at 6.3bar inlet pressure 0.5 dm<sup>3</sup>/s  
 Typical flow with 6.3bar inlet pressure and 0.7 bar pressure drop: 184 dm<sup>3</sup>/s

**Material Specification**

Body:	Aluminium
Bowl sight glass:	Polypropylene
Sight dome:	Polyamide
Lubricator cover:	ABS
Bayonet support:	Nylon
Seals:	Nitrile NBR

**Dimensions (mm)**

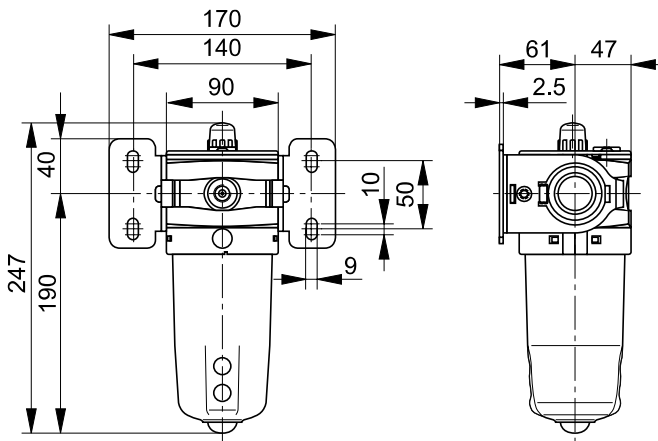

**Flow characteristics**

**(3/4) Lubricator**

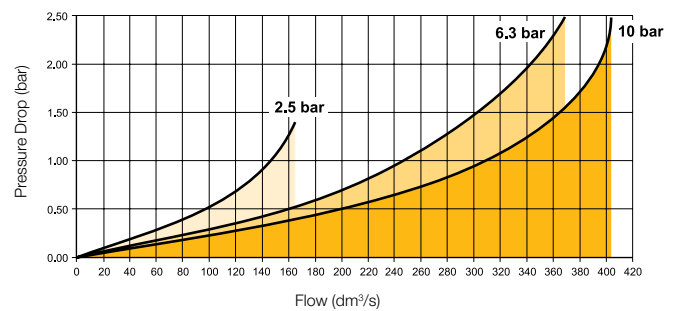

**(1") Lubricator**

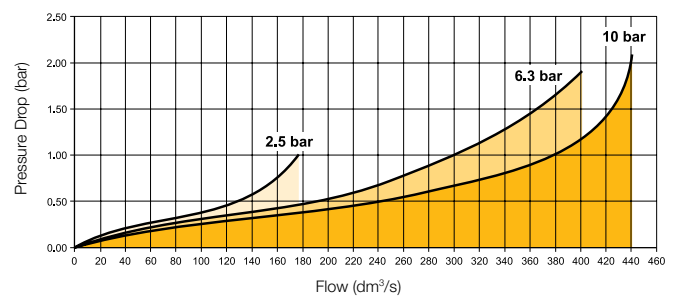

**Service kits**

Description	Order code
Bowl kit	<b>P3YKA00BSN</b>
Refill plug	<b>P3YKA00PL</b>
Lubricator Oil	<b>P3YKA00PPBB</b>

**Proportional Pressure Regulator**



- Integral 3/4 or 1" ports (BSPP & NPT)
- Accurate output pressure
- Very fast response times
- Robust but lightweight design.

**Options:**

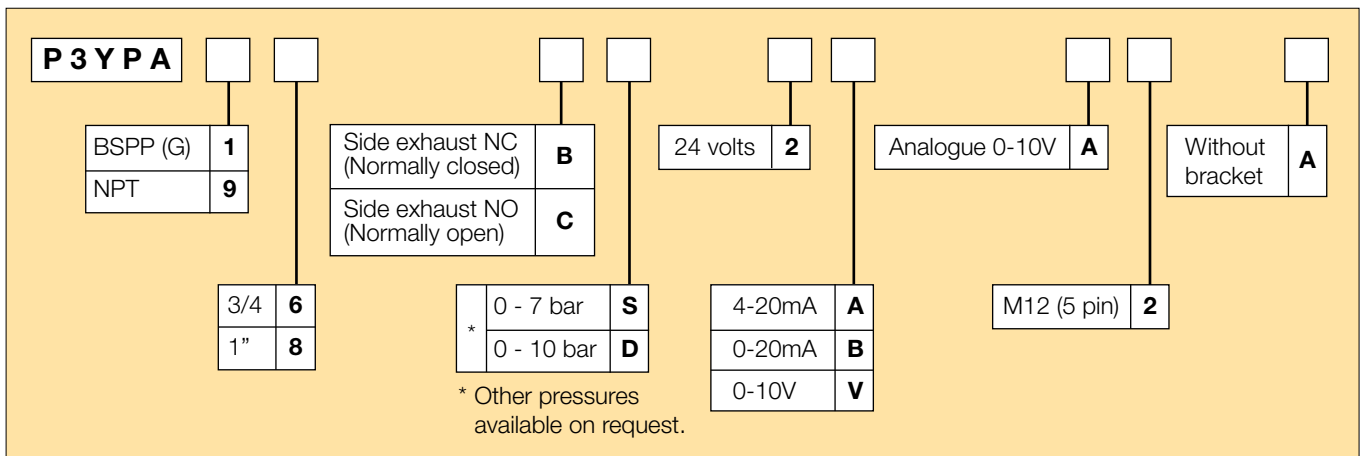

**Popular options:**

Port size	Description	Order Code	Control signal	Output signal	Output pressure	Weight kg
3/4	Normally closed	<b>P3YPA16BD2VA2A</b>	0 - 10 V	0 - 10 V	0 - 10 bar	1.2
1"	Normally closed	<b>P3YPA18BD2VA2A</b>	0 - 10 V	0 - 10 V	0 - 10 bar	1.2

**Technical Information**

Operating pressure range	P <sup>1</sup> min	1 bar
Inlet pressure <sup>1)</sup>	P <sup>1</sup> max	16 bar
Operating pressure range	P <sup>2</sup> min	0.2 bar
Outlet pressure	P <sup>2</sup> max	10 bar
Operating Temperature	0°C to +50°C	
Maximum Flow	Qn	l/min 20000
		m <sup>3</sup> /h 1200
Hysteresis	P <sup>2</sup> max	< 1%
Repeatability	P <sup>2</sup> max	< 0.5%
Sensitivity	P <sup>2</sup> max	< 0.5%
Linearity	P <sup>2</sup> max	< 1%
Nominal voltage	U <sub>n</sub>	V DC 24V = ±10%
Residual ripple	10%	
Power consumption	I <sub>Bmax</sub>	0.15 A
Set value input	U <sub>w</sub>	V 0 - 10
	I	mA 0 - 20
		mA 4 - 20
Input resistance	R <sub>E</sub>	243 K Ω
Actual valve output	U <sub>x</sub>	0 - 10 V
Ouput current	I <sub>Amax</sub>	10 mA
Degree of protection	IP65 to DIN 40050, EN 60529	

<sup>1)</sup> p<sub>1</sub> > p<sub>2</sub> + 10% p<sub>2</sub>

<sup>2)</sup> at p<sub>1</sub> - 10 bar to p<sub>2</sub> - 6.3 bar

**Dimensions (mm)**

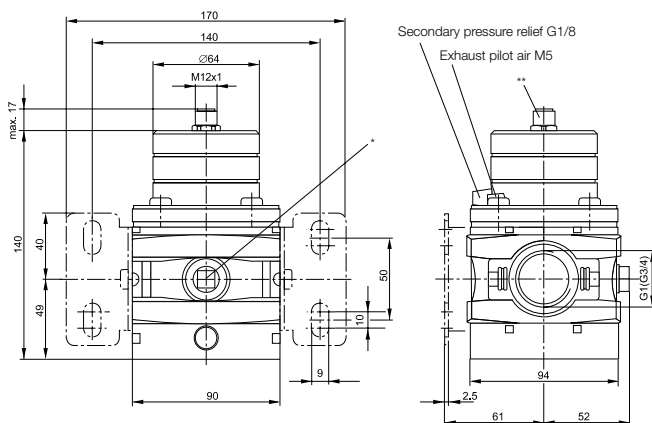

\* Two opposite gauge ports G1/4, plug screw mounted

\*\* Connection for 5-pin plug M12 x 1

**Material Specification**

Housing:	Aluminium
Pilot valve booster:	Brass / NBR composite aluminium
Standard seals:	NBR
Body cover screws:	Steel / zinc plated

**Connection diagram**

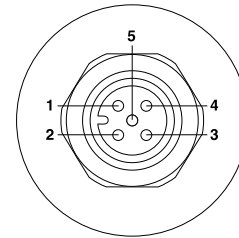

**Connector M12 x 1**

**Pin 1:**  
 Power supply  
 Plus +24 V DC ± 10%  
 0.15 A  
 Residual ripple 10%

**Pin 2:**  
 Power supply 0 V  
 Reference and mass capacity  
 for set value and actual value

**Pin 3:**  
 Set value input  
 0 - 10 V

**Pin 4:**  
 0 V set signal  
 (connected on board  
 with pin 2 as standard)

**Pin 5:**  
 Analogue actual value output  
 0 - 10 V  
 Tolerance ± 0.15 V

**Flow characteristics**

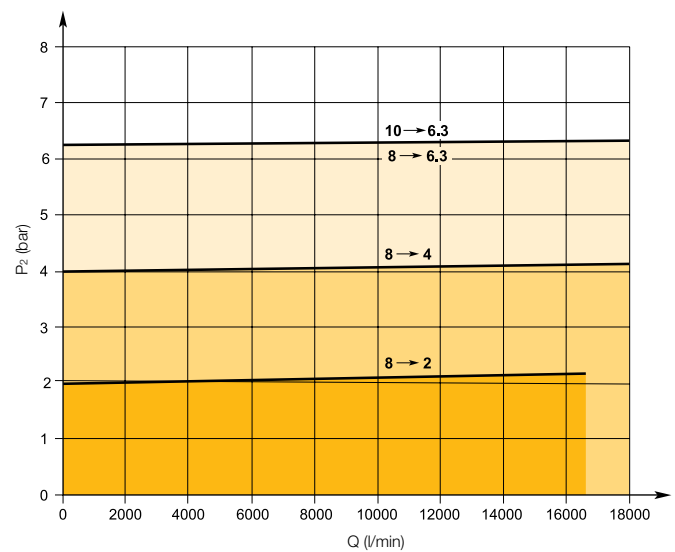

**Combined Soft Start Dump Valve and Remote Operated Dump Valve**



**Symbols**

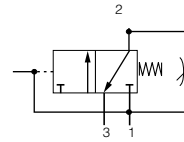

- Modular design with 3/4 & 1" integral ports (BSPP or NPT)
- Provides for the safe introduction of pressure
- Automatically dumps downstream pressure on the loss of pilot signal
- Adjustable slow start
- Solenoid or air pilot options
- High flow & exhaust capability

P3Y Series Combined Soft Start/Dump Valves, provide for the safe introduction of pressure to machines or systems. Soft Start/Dump Valves when set, allow the pressure to gradually build to the set point before fully opening to deliver full flow at line pressure.

The controlled introduction of pressure can be an important safety factor and prevent damage to tooling when air pressure is introduced at machine or system start up.

**Options:**

<b>P3YTA</b>					<b>N</b>		<b>Solenoid type only</b>	
BSPP (G)	<b>1</b>		External air pilot	<b>P</b>	None (operator is fitted to valve)	<b>0</b>	Solenoid / coil not fitted	<b>000</b>
NPT	<b>9</b>		Solenoid pilot	<b>S</b>	30mm CNOMO coil (Form connection)	<b>A</b>	24V DC	<b>2CN</b>
		3/4	30mm operator	<b>C</b>	22mm coil (Form connection)	<b>B</b>		
		1"	Threaded air pilot	<b>P</b>	30mm CNOMO coil (M12 connection)	<b>D</b>		
					22mm coil (M12 connection)	<b>E</b>		
<b>For ATEX Order:</b>								
<b>P3YTA</b>			<b>PPNX</b>					

**Combined soft start dump valve**

Port size	Description	Order Code	Flow dm <sup>3</sup> /s	Max bar	Min temp °C	Max temp °C	Height mm	Width mm	Depth mm	Weight kg
3/4	Solenoid operated (not included)	<b>P3YTA16SCN0000</b>	175	16	-10	60	130	90	104	1.5
3/4	24VDC 22mm coil	<b>P3YTA16SCNB2CN</b>	175	16	-10	60	191	90	104	1.6
3/4	Air pilot operated	<b>P3YTA16PPN</b>	175	17.5	-10	60	145	90	104	1.4
1"	Solenoid operated (not included)	<b>P3YTA18SCN0000</b>	200	16	-10	60	130	90	104	1.5
1"	24VDC 22mm coil	<b>P3YTA18SCNB2CN</b>	200	16	-10	60	191	90	104	1.6
1"	Air pilot operated	<b>P3YTA18PPN</b>	200	17.5	-10	60	130	90	104	1.4

**Technical Information**

Fluid:	Compressed air	
Maximum pressure Solenoid operated:	16 bar	
Maximum pressure Air Pilot operated:	17.5 bar	
Minimum operating pressure:	2 bar	
Temperature range* Solenoid operated:	-10° to + 60° C	
Temperature range* Air Pilot operated:	-10° to + 60° C	
Air Pilot port:	1/8"	
Exhaust port:	1"	
Gauge port:	1/4"	
Typical flow with 6.3bar inlet pressure and 1 bar pressure drop:	3/4"	175 dm <sup>3</sup> /s
	1"	200 dm <sup>3</sup> /s

\* Air supply must be dry enough to avoid ice formation at temperatures below +2°C  
 Snap pressure: Full flow when downstream pressure reaches 50% of the inlet pressure

**Dimensions (mm)**

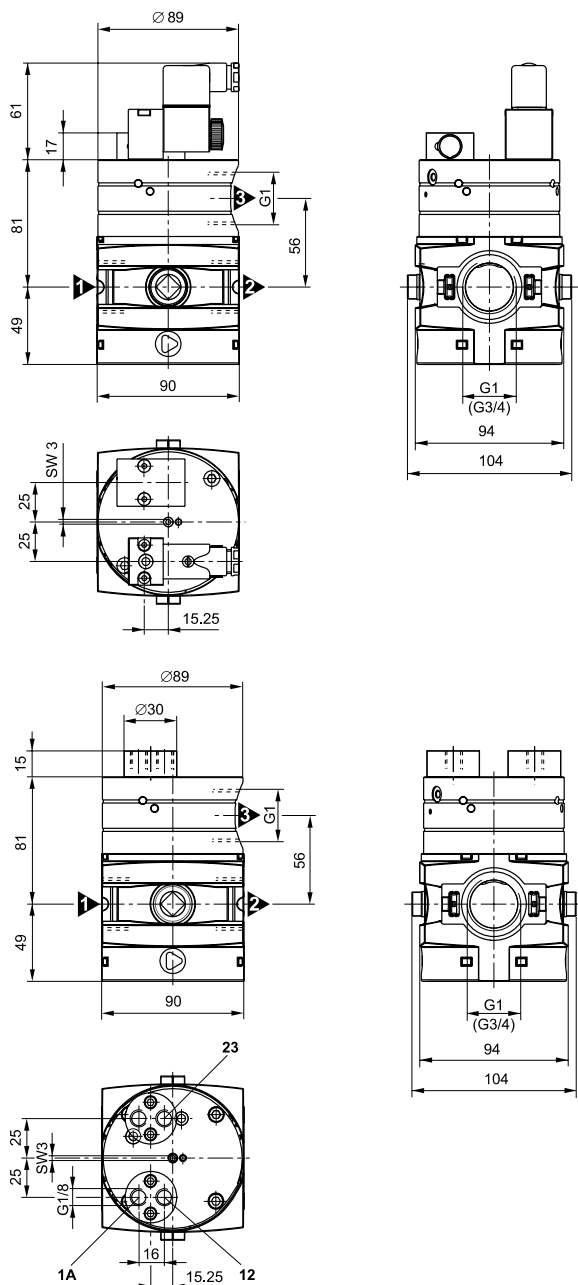

**Material Specification**

Body:	Aluminium
Body cover:	ABS
Valve:	Brass / NBR composite
Pilot valve booster:	Aluminium
Seals:	Nitrile NBR

**Note:** For solenoid coil and cable plug options see page 30.

**Flow characteristics**

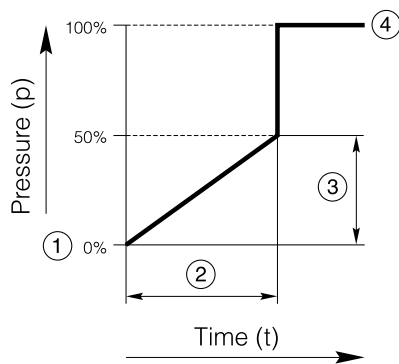

- ① Start signal
- ② Switching time delay
- ③ Gradual pressure build up
- ④ Operating pressure  $p^2 (=p^1)$

**Combined start/stop function**

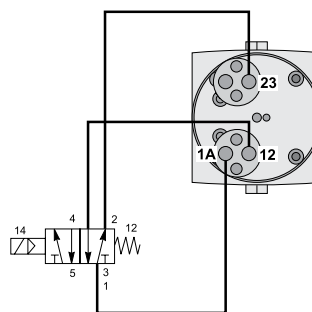

**Combined start/stop function with acknowledgement**

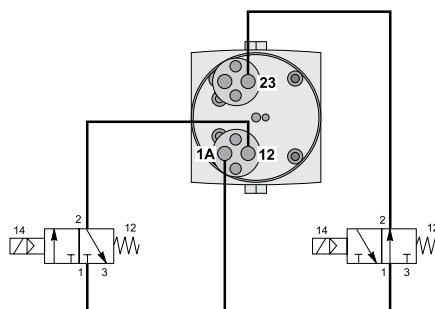

**Soft Start Valve**



**Symbols**

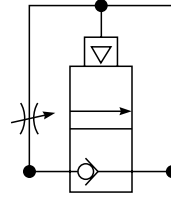

- Integral 3/4" or 1" ports
- Smooth start-up of pneumatic system
- Air pilot operation
- Adjustable slow start
- High flow

**Options:**

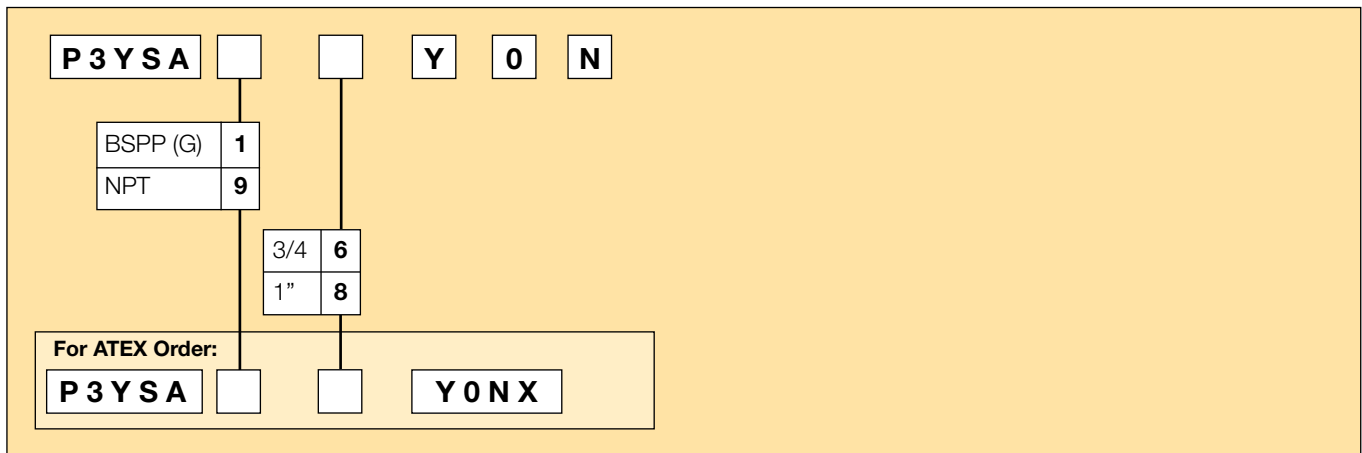

**Soft start valve**

Port size	Description	Order Code	Flow dm <sup>3</sup> /s	Max bar	Min temp °C	Max temp °C	Height mm	Width mm	Depth mm	Weight kg
3/4	Soft start valve	<b>P3YSA16Y0N</b>	153	175	-10	60	85	90	97	0.8
1"	Soft start valve	<b>P3YSA18Y0N</b>	180	175	-10	60	85	90	97	0.8



**Technical Information**

Fluid:	Compressed air
Maximum pressure Air Pilot operated:	17.5 bar
Minimum operating pressure:	2 bar
Temperature range* Solenoid operated:	-10° to + 60° C
Temperature range* Air Pilot operated:	-10° to + 60° C
Typical flow with 6.3bar inlet pressure and 1 bar pressure drop:	180 dm <sup>3</sup> /s

\* Air supply must be dry enough to avoid ice formation at temperatures below +2°C  
 Snap pressure: Full flow when downstream pressure reaches 50% of the inlet pressure

**Material Specification**

Body:	Aluminium
Body cover:	ABS
Valve:	Brass / NBR composite
Pilot valve booster:	Aluminium
Seals:	Nitrile NBR

**Dimensions (mm)**

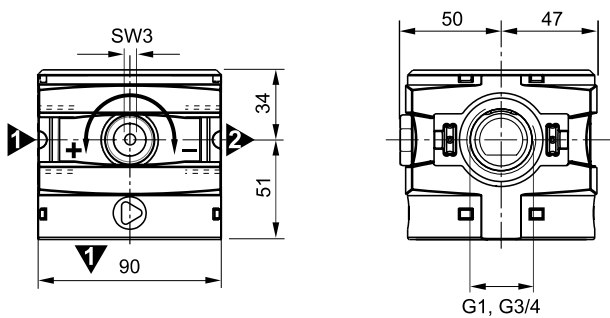

**Flow characteristics**

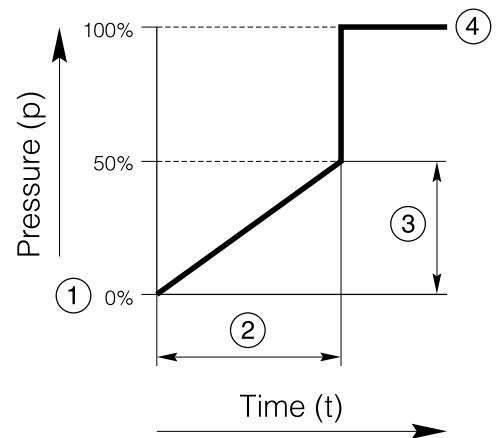

- ① Start signal
- ② Switching time delay
- ③ Gradual pressure build up
- ④ Operating pressure  $p^2 (=p^1)$

**Pilot Operated Regulator**

**Symbol**

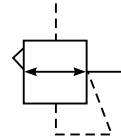

- Integral 3/4 or 1" ports (BSPP & NPT)
- Pilot controlled regulators can be mounted 'out of reach' with pilot regulator installed in a convenient location
- Constant pilot bleed control for accurate pressure control
- Balanced poppet provides quick response
- High flow

**Options:**

<b>P 3 Y</b>	<b>R A</b>			<b>B P P N</b>
		BSPP (G) <b>1</b>	G3/4 <b>6</b>	
		NPT <b>9</b>	G1 <b>8</b>	

**Pilot Operated Regulator**

Port size	Description	Order Code	Flow dm³/s	Max bar	Min temp °C	Max temp °C	Height mm	Width mm	Depth mm	Weight kg
3/4	Pilot operated regulator	<b>P3YRA16BPPN</b>	333	17.5	-10	60	105.5	90	90	1.2
1"	Pilot operated regulator	<b>P3YRA18BPPN</b>	340	17.5	-10	60	105.5	90	90	1.2

\* Flow with 10 bar inlet pressure, 6.3 bar set pressure and 1 bar pressure drop.

**Technical Information**

Flow Capacity:	3/4	333 dm <sup>3</sup> /s
	1"	340 dm <sup>3</sup> /s
Operating Temperature:	-10°C to +60°C	
Maximum Supply Pressure:	17.5 bar	
Weight (g):	3/4	1.2 kg
	1"	1.2 kg

**Material specification:**

Body:	Aluminium
Body cover:	ABS
Seals:	Nitrile NBR
Screws:	Zinc plated steel
Valve:	Brass / NBR composite
Pilot valve booster:	Aluminium

**Dimensions (mm)**

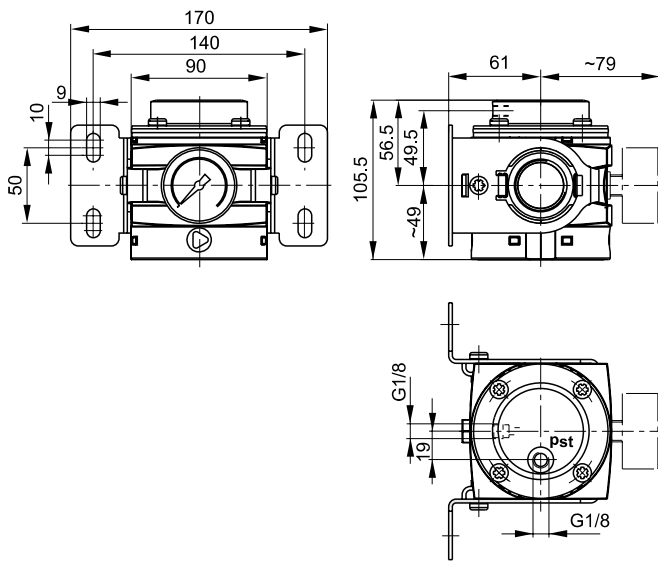

**Flow characteristics**

**Pilot Operated Regulator**

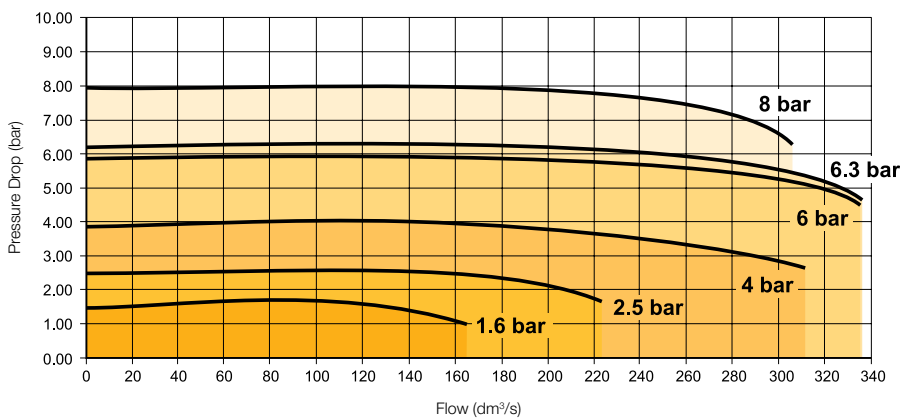

**Modular Ball Valve**



**Symbols**

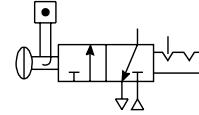

- Positive bubble tight shut-off.
- 90° turn handle to prevent unauthorised adjustment.
- Padlockable (up to 6 times).
- When the inlet pressure is turned off the downstream vents through the exhaust port.

P3Y Series Ball Valves provide shut off line pressure with a non-sticking 90° turn handle to prevent unauthorised adjustment. When the inlet pressure is turned off the downstream vents through the exhaust port.

**Options:**

<b>P 3 Y</b>	<b>V A</b>	□	□	<b>L B N</b>	
		BSPP (G)	<b>1</b>	3/4"	<b>6</b>
		NPT	<b>9</b>	1"	<b>8</b>

**Technical Information**

Flow Capacity:	3/4	333 dm <sup>3</sup> /s
	1"	333 dm <sup>3</sup> /s
Operating Temperature:	-10°C to +60°C	
Maximum Supply Pressure:	17.5 bar	
Weight (kg):	3/4	1.1
	1"	1.1

**Material specification:**

Body:	Aluminium
Valve ball:	Brass / Nickle plated
Handle:	Aluminium
Seals:	Nitrile NBR
Exhaust silencer:	Sintered bronze

**Dimensions (mm)**

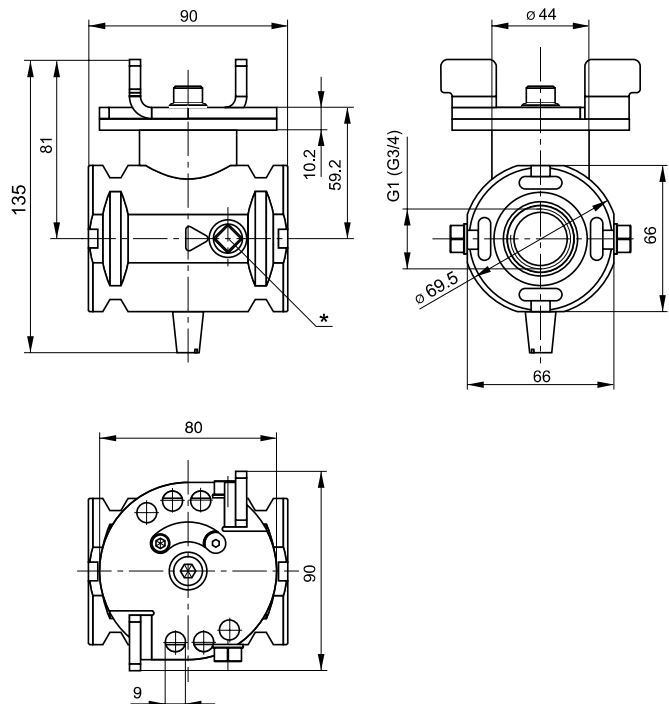

**Modular Manifold**



P3Y Series Manifolds, provide up to 4 extra outlet ports, they may be assembled at any position in a combination e.g. before the lubricator to provide oil free take off or at the end of a combination to provide extra outlet ports.

Thread type	Order code
BSPP	<b>P3YMA1V0N</b>
NPT	<b>P3YMA9V0N</b>

Inlet port	Top	Bottom	Front and Back
3/4"	1/8"	1"	1/4"
1"	1/8"	1"	1/4"

**Material specification:**

Body:	Aluminium
Weight (kg):	0.7

**Dimensions (mm)**

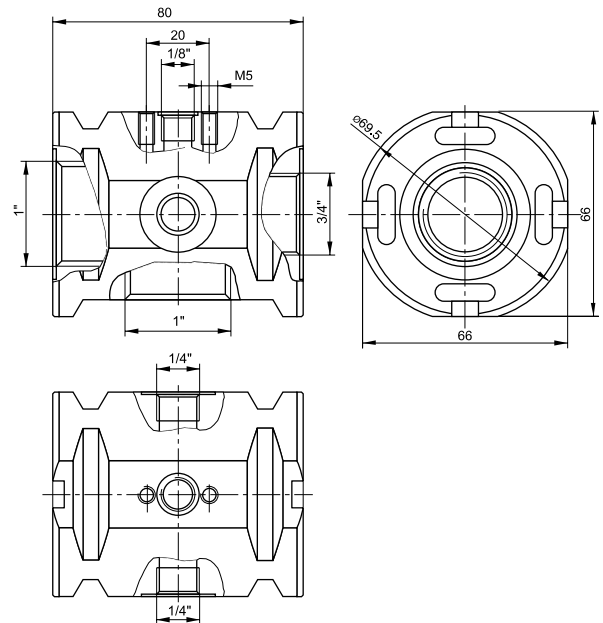

**Optional Port Block Kits**



- To change port sizes Port Block Kits are available, they are attached to any unit utilising the connecting kit.
- Allows assemblies to be removed from a hard piped system.

**Options:**

<b>P 3 Y K A</b>	<input type="checkbox"/>	<input type="checkbox"/>	<b>C P</b>
BSPP (G)	<b>1</b>	1 1/4"	<b>A</b>
NPT	<b>9</b>	1 1/2"	<b>B</b>

**Material specification:**

Body:	Aluminium
Weight (kg):	0.65

### Solenoid coils with Din A or Industrial B connection

Voltage	30mm x 30mm Order code DIN A Standard	Weight (Kg)	22mm x 30mm Order code Industrial B standard	Weight (Kg)
Direct current				
12V DC	<b>P2FCA445</b>	0.105	<b>P2FCB445</b>	0.093
24V DC	<b>P2FCA449</b>	0.105	<b>P2FCB449</b>	0.093
48V DC	<b>P2FCA453*</b>	0.105	<b>P2FCB451</b>	0.093
Alternative current				
12V 50/60Hz	<b>P2FCA440</b>	0.105	<b>P2FCB440</b>	0.093
24V 50/60Hz	<b>P2FCA442</b>	0.105	<b>P2FCB442</b>	0.093
48V 50/60Hz	<b>P2FCA469<sup>#</sup></b>	0.105		
110V 50Hz, 120V 60Hz	<b>P2FCA453</b>	0.105	<b>P2FCB453</b>	0.093
230V 50Hz, 230V 60Hz	<b>P2FCA457</b>	0.105	<b>P2FCB457</b>	0.093

\* P2FCA453 is compatible with 110 V AC and 48 V DC

# P2FCA469 is 24 V DC 6.8W or 48 V 50Hz 9.9 VA

### Solenoid coils with M12 connection

Voltage	Order code Form A 30 x 30	Weight (Kg)	Order code Form B 22 x 30	Weight (Kg)
Direct current				
24V DC	<b>P2FC6419</b>	0.065	<b>P2FC7419</b>	0.065

**Accessories**

Description	Connection	Weight (kg)	Order code	
Panel mounting nut (Aluminium)		0.70	<b>P3YKA00MM</b>	
Neck mounting bracket kit		3.75	<b>P3YKA00MS</b>	
Wall mounting brackets		0.2	<b>P3YKA00CW</b>	
P3Y connecting kit		0.05	<b>P3YKA00CB</b>	
Regulator & Filter/Regulator - Key Lock Kit		0.05	<b>P3XKA00AS</b>	
Pressure gauge	0 to 10 bar 0 to 16 bar	1/4" 1/4"	<b>KG8012-00</b> <b>KG8013-00</b>	
Lubricator Oil	VG32 - 1 litre	0.92	<b>P3YKA00PPBB</b>	
Connector O-ring kit	Qty: 5		<b>P3YKA08CY</b>	

# Parker Worldwide

**AE – UAE, Dubai**  
Tel: +971 4 8127100  
parker.me@parker.com

**AR – Argentina, Buenos Aires**  
Tel: +54 3327 44 4129

**AT – Austria, Wiener Neustadt**  
Tel: +43 (0)2622 23501-0  
parker.austria@parker.com

**AT – Eastern Europe, Wiener Neustadt**  
Tel: +43 (0)2622 23501 900  
parker.easteurope@parker.com

**AU – Australia, Castle Hill**  
Tel: +61 (0)2-9634 7777

**AZ – Azerbaijan, Baku**  
Tel: +994 50 2233 458  
parker.azerbaijan@parker.com

**BE/LU – Belgium, Nivelles**  
Tel: +32 (0)67 280 900  
parker.belgium@parker.com

**BR – Brazil, Cachoeirinha RS**  
Tel: +55 51 3470 9144

**BY – Belarus, Minsk**  
Tel: +375 17 209 9399  
parker.belarus@parker.com

**CA – Canada, Milton, Ontario**  
Tel: +1 905 693 3000

**CH – Switzerland, Etoy**  
Tel: +41 (0) 21 821 02 30  
parker.switzerland@parker.com

**CL – Chile, Santiago**  
Tel: +56 2 623 1216

**CN – China, Shanghai**  
Tel: +86 21 2899 5000

**CZ – Czech Republic, Klecany**  
Tel: +420 284 083 111  
parker.czechrepublic@parker.com

**DE – Germany, Kaarst**  
Tel: +49 (0)2131 4016 0  
parker.germany@parker.com

**DK – Denmark, Ballerup**  
Tel: +45 43 56 04 00  
parker.denmark@parker.com

**ES – Spain, Madrid**  
Tel: +34 902 330 001  
parker.spain@parker.com

**FI – Finland, Vantaa**  
Tel: +358 (0)20 753 2500  
parker.finland@parker.com

**FR – France, Contamine s/Arve**  
Tel: +33 (0)4 50 25 80 25  
parker.france@parker.com

**GR – Greece, Athens**  
Tel: +30 210 933 6450  
parker.greece@parker.com

**HK – Hong Kong**  
Tel: +852 2428 8008

**HU – Hungary, Budapest**  
Tel: +36 1 220 4155  
parker.hungary@parker.com

**IE – Ireland, Dublin**  
Tel: +353 (0)1 466 6370  
parker.ireland@parker.com

**IN – India, Mumbai**  
Tel: +91 22 6513 7081-85

**IT – Italy, Corsico (MI)**  
Tel: +39 02 45 19 21  
parker.italy@parker.com

**JP – Japan, Tokyo**  
Tel: +(81) 3 6408 3901

**KR – South Korea, Seoul**  
Tel: +82 2 559 0400

**KZ – Kazakhstan, Almaty**  
Tel: +7 7272 505 800  
parker.easteurope@parker.com

**LV – Latvia, Riga**  
Tel: +371 6 745 2601  
parker.latvia@parker.com

**MX – Mexico, Apodaca**  
Tel: +52 81 8156 6000

**MY – Malaysia, Shah Alam**  
Tel: +60 3 7849 0800

**NL – The Netherlands, Oldenzaal**  
Tel: +31 (0)541 585 000  
parker.nl@parker.com

**NO – Norway, Ski**  
Tel: +47 64 91 10 00  
parker.norway@parker.com

**NZ – New Zealand, Mt Wellington**  
Tel: +64 9 574 1744

**PL – Poland, Warsaw**  
Tel: +48 (0)22 573 24 00  
parker.poland@parker.com

**PT – Portugal, Leca da Palmeira**  
Tel: +351 22 999 7360  
parker.portugal@parker.com

**RO – Romania, Bucharest**  
Tel: +40 21 252 1382  
parker.romania@parker.com

**RU – Russia, Moscow**  
Tel: +7 495 645-2156  
parker.russia@parker.com

**SE – Sweden, Spånga**  
Tel: +46 (0)8 59 79 50 00  
parker.sweden@parker.com

**SG – Singapore**  
Tel: +65 6887 6300

**SK – Slovakia, Banská Bystrica**  
Tel: +421 484 162 252  
parker.slovakia@parker.com

**SL – Slovenia, Novo Mesto**  
Tel: +386 7 337 6650  
parker.slovenia@parker.com

**TH – Thailand, Bangkok**  
Tel: +662 717 8140

**TR – Turkey, Istanbul**  
Tel: +90 216 4997081  
parker.turkey@parker.com

**TW – Taiwan, Taipei**  
Tel: +886 2 2298 8987

**UA – Ukraine, Kiev**  
Tel: +380 44 494 2731  
parker.ukraine@parker.com

**UK – United Kingdom, Warwick**  
Tel: +44 (0)1926 317 878  
parker.uk@parker.com

**US – USA, Cleveland**  
Tel: +1 216 896 3000

**VE – Venezuela, Caracas**  
Tel: +58 212 238 5422

**ZA – South Africa, Kempton Park**  
Tel: +27 (0)11 961 0700  
parker.southafrica@parker.com

European Product Information Centre  
Free phone: 00 800 27 27 5374  
(from AT, BE, CH, CZ, DE, DK, EE, ES, FI,  
FR, IE, IL, IS, IT, LU, MT, NL, NO, PL, PT, RU,  
SE, UK, ZA)

